

# PT9232

## Heavy Industrial • RS232 Communication

Linear Position/Velocity to 550 inches (1400 cm)  
 Aluminum or Stainless Steel Enclosure Options  
 VLS Option To Prevent Free-Release Damage  
 IP68 • NEMA 6 Protection • Hazardous Area Certification



### GENERAL

Full Stroke Ranges	0-75 to 0-550 inches
Electrical Interface	RS232
Format	HEX
Accuracy	± 0.10% full stroke
Repeatability	± 0.02% full stroke
Resolution	± 0.003% full stroke
Measuring Cable	stainless steel or thermoplastic
Enclosure Material	powder-painted aluminum or 303 stainless steel
Sensor	plastic-hybrid precision potentiometer
Potentiometer Cycle Life	≥ 250,000 cycles
Maximum Retraction Acceleration	see ordering information
Maximum Velocity	see ordering information
Weight, Aluminum (Stainless Steel) Enclosure	8 lbs. (16 lbs.), max.

### ELECTRICAL

Input Voltage	9...22 VDC
Input Current	40 mA
Baud Rate	9600 (selectable to 38.4K)
Update Rate	32 msec

### ENVIRONMENTAL

Enclosure	NEMA 4/4X/6, IP 67/68
Operating Temperature	-40° to 200°F (-40° to 90°C)
Vibration	up to 10 g to 2000 Hz maximum

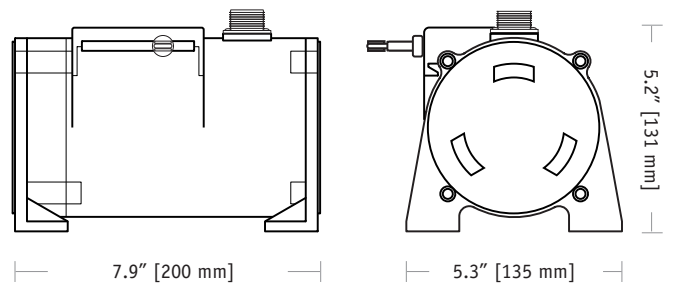

The PT9232 delivers position feedback via RS232 serial communication to your data acquisition or controller system. The PT9232 sends a raw 16-bit count from 0000H to FFFFH. Additionally this device can be set to continuously send data or send data only when polled.

As the internal position sensing element is a precision potentiometer, this transducer maintains current accurate position even during power loss and does not need to be reset to a "home" position.

### Output Signal:

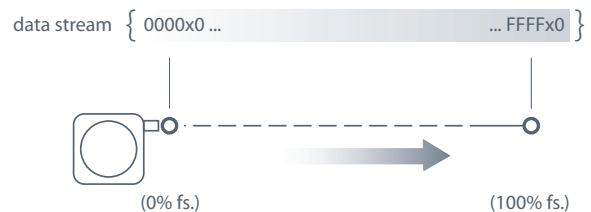

20630 Plummer Street • Chatsworth, CA 91311  
 tel: 800.423.5483 • +1.818.701.2750 • fax: +1.818.701.2799

**celesco**  
 celesco.com • info@celesco.com

## I/O Format

### Data Format

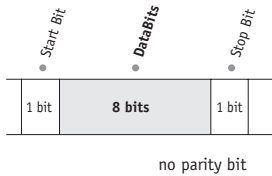

### Data Frame

6 byte Hex string:

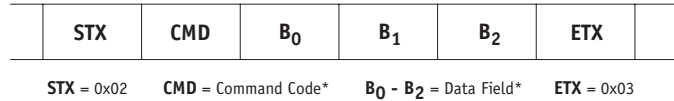

\*-see below

**Important!** All communications to/from the transducer are in **HEX!**

#### User Commands:

Description	User Command				Sensor Response			
	<CMD>	<B <sub>0</sub> >	<B <sub>1</sub> >	<B <sub>2</sub> >	<CMD>	<B <sub>0</sub> >	<B <sub>1</sub> >	<B <sub>2</sub> >
Get Sensor Info	0x05	0x00	0x00	0x00	0x05	version <sup>(4)</sup>	date <sup>(5)</sup>	date <sup>(5)</sup>
Get Serial Number	0x15	0x00	0x00	0x00	0x15	serial number <sup>(3)</sup>		
Start Continuous Data	0x25	0x00	0x00	0x00	0x25	0x00	0x00	0x00
Stop Continuous Data	0x35	0x00	0x00	0x00	0x35	0x00	0x00	0x00
Get Position Data	0x45	0x00	0x00	0x00	0x45	CMC <sup>(1)</sup>	CMC <sup>(1)</sup>	status <sup>(2)</sup>

#### (1) CMC - Current Measurement Count (Position)

The **Current Measurement Count (CMC)** is the output data that indicates the present position of the measuring cable.

The CMC is a 16-bit value that occupies the first two bytes (B<sub>0</sub> and B<sub>1</sub>) of the data field. B<sub>0</sub> is the MSB (most significant byte) and B<sub>1</sub> is the LSB (least significant byte).

The CMC starts at 0000H with the measuring cable fully retracted and continues upward to the end of the stroke range stopping at FFFFH. This holds true for all ranges.

#### (2) Status

The status byte is used as a flag to indicate the validity of the position signal that the internal electronics receives from the potentiometer.

Flags are as follows:

0x00 = GREEN, 0x55 = YELLOW, 0xAA = RED

A "green" flag shows everything OK. A "yellow" or "red" flag indicates that the sensor has either been extended beyond its range or that there is a problem with the potentiometer.

#### (5) Date

This is a 2 byte value showing the date of currently installed firmware. This value ranges from 01011 - 12319 (decimal). Format is MMDDY. While the month and day are expressed as two digit numbers the year is expressed in a single digit only.

Example: 08054 = August 5, 2004

#### (3) Serial Number

Each sensor has its own unique serial number. This information can be retrieved by sending the sensor the "Get Serial Number" command.

The serial number is a 3 byte value from which ranges from 0 to 9999999 (decimal).

#### (4) Version

This is a single byte value (0-255 decimal) which indicates the currently installed firmware version of the sensor.

#### Baud Rate

The baud rate can be set using switches 7 & 8 on the 8-pole DIP switch found on the rs232 controller board located inside the transducer.

DIP-7	DIP-8	baud rate
0	0	9600
1	0	19200
0	1	38400
1	1	9600



#### RS232 Controller Board and DIP Switch Location

##### baud rate switches

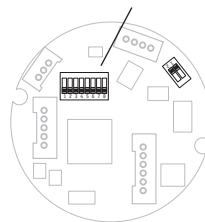

**Caution!** Do Not Remove Spring-Side End Cover  
removing spring-side end cover could cause spring to become unseated and permanently damaged.

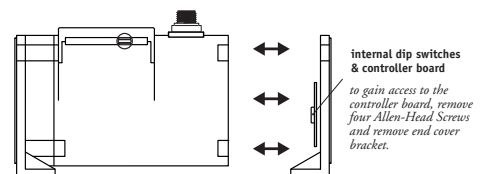
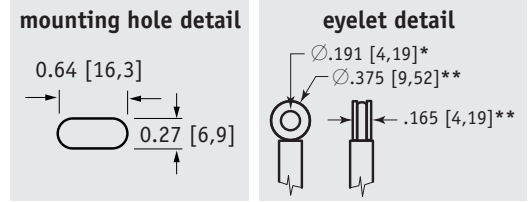
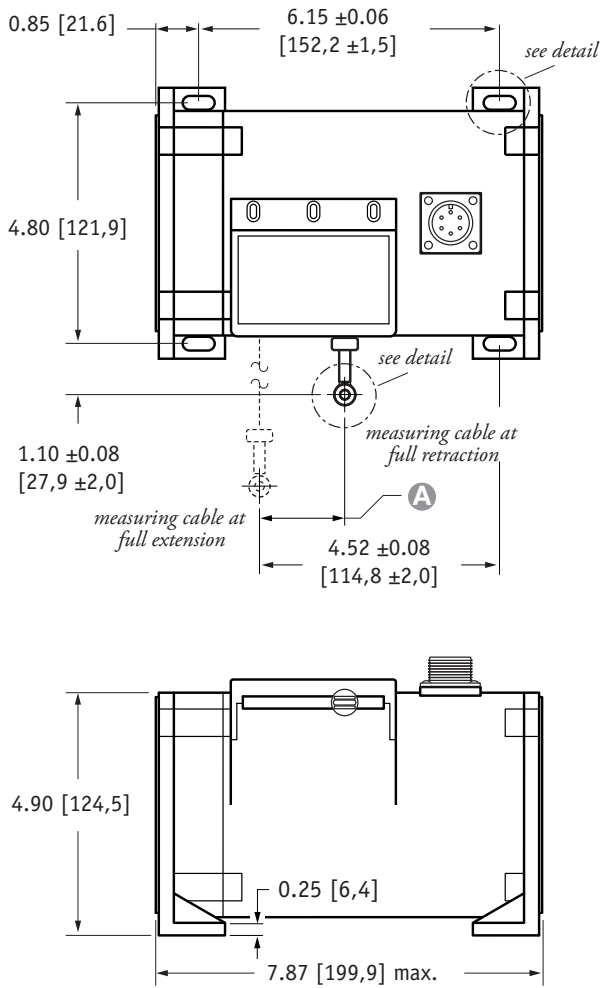
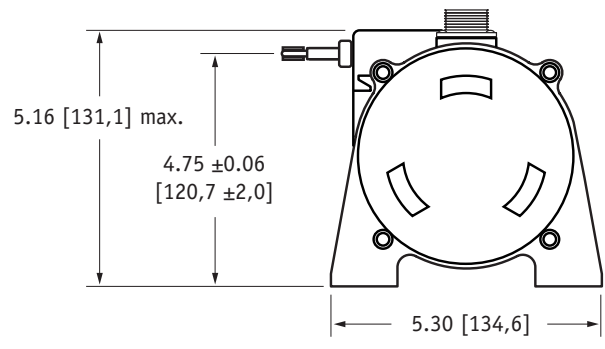

Fig. 1 – Outline Drawing (18 oz. cable tension only)



**A DIMENSION (INCHES)**

RANGE	MEASURING CABLE		
	Ø.034 in.	Ø.047 in.	Ø.062 in.
75	0.22	0.29	0.37
100	0.29	0.39	0.49
150	0.44	0.59	0.73
200	0.58	0.79	0.98
250	0.73	0.98	1.22
300	0.88	1.18	1.47
350	1.02	1.38	1.71
400	1.17	1.57	1.96
450	1.31	1.77	n/a
500	1.46	1.97	n/a
550	1.61	n/a	n/a



DIMENSIONS ARE IN INCHES [MM]  
tolerances are 0.03 IN. [0.5 MM] unless otherwise noted.

\* tolerance = +.005 -.001 [+,.13 -.03]  
\*\* tolerance = +.005 -.005 [+,.13 -.13]

Ordering Information:

**Model Number:**

**PT9232** - \_\_\_\_\_  
order code:            **R**        **A**        **B**        **C**        **D**        **E**

Sample Model Number:

**PT9232 - 200 - AL - N34 - 26 - FR - M6**

- R** range: 200 inches
- A** enclosure: aluminum
- B** measuring cable: .034 nylon-coated stainless
- C** measuring cable tension: 18 oz.
- D** cable exit: front (horizontal)
- E** electrical connection: 6-pin plastic connector

**Full Stroke Range:**

<b>R</b> order code:	75	100	150	200	250	300	350	400	450*	500*	550*
full stroke range, min:	75 in.	100 in.	150 in.	200 in.	250 in.	300 in.	350 in.	400 in.	450 in.	500 in.	550 in.

\* - 36 oz. cable tension strongly recommended

Ordering Information (cont.):

**Enclosure Material:**

<b>A</b> order code:	<b>AL</b>	<b>SS</b>
	powder-painted aluminum	303 stainless

**Measuring Cable:**

<b>B</b> order code:	<b>N34</b>	<b>S47</b>	<b>V62</b>
	∅.034-inch nylon-coated stainless steel available in <b>all</b> ranges	∅.047-inch stainless steel all ranges up to <b>500 inches</b>	∅.062-inch thermoplastic all ranges up to <b>400 inches</b>

**Measuring Cable Tension:**

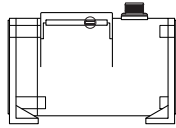
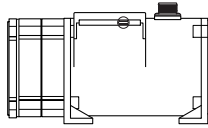
<b>C</b> order code:	<b>26</b>		<b>52</b>	
tension (30%):	18 oz.		36 oz.	
enclosure material:	aluminum	stainless steel	aluminum	stainless steel
max. acceleration:	1 G	.33 G	5 G	2 G
max. velocity:	60 inches/sec	20 inches/sec	200 inches/sec	80 inches/sec
	 standard housing see fig 1.		 dual-spring housing see fig 2.	

**Cable Exit:**

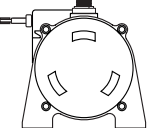
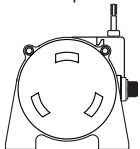
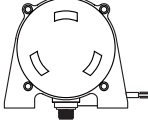
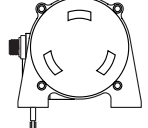
<b>D</b> order code:	<b>FR</b>	<b>UP</b>	<b>BK</b>	<b>DN</b>
	front	top	back	down
				

**Electrical Connection:**



<b>E</b> order code:	<b>M6</b>	<b>C25</b>																												
	6-pin plastic connector with mating plug IP 67, NEMA 6, NEMA 4X (stainless enclosure only)	25-ft. instrumentation cable 24 AWG, shielded IP 67, NEMA 6																												
	 <p>3.0 in. [78 mm]</p> <p>.30 - .39 in. [8 - 10 mm] cable dia. 16 AWG max conductor size connector: MS3102E-14S-6P mating plug: MS3106E-14S-6S</p>	 <p>25 ft. x 0.2-in. dia. [7,5 M x 5 mm dia.] 24 AWG, shielded</p>																												
	 <p>contact view</p> <table border="1"> <tr> <th>pin</th> <th>signal</th> </tr> <tr> <td>A</td> <td>9...22 VDC</td> </tr> <tr> <td>B</td> <td>common</td> </tr> <tr> <td>C</td> <td>-</td> </tr> <tr> <td>D</td> <td>Transmitted Data</td> </tr> <tr> <td>E</td> <td>Received Data</td> </tr> <tr> <td>F</td> <td>common</td> </tr> </table>	pin	signal	A	9...22 VDC	B	common	C	-	D	Transmitted Data	E	Received Data	F	common	<table border="1"> <tr> <th>color code</th> <th>signal</th> </tr> <tr> <td>Red</td> <td>9...22 VDC</td> </tr> <tr> <td>Black</td> <td>common</td> </tr> <tr> <td>White</td> <td>-</td> </tr> <tr> <td>Green</td> <td>Transmitted Data</td> </tr> <tr> <td>Blue</td> <td>Received Data</td> </tr> <tr> <td>Brown</td> <td>common</td> </tr> </table>	color code	signal	Red	9...22 VDC	Black	common	White	-	Green	Transmitted Data	Blue	Received Data	Brown	common
pin	signal																													
A	9...22 VDC																													
B	common																													
C	-																													
D	Transmitted Data																													
E	Received Data																													
F	common																													
color code	signal																													
Red	9...22 VDC																													
Black	common																													
White	-																													
Green	Transmitted Data																													
Blue	Received Data																													
Brown	common																													

Fig. 2 – Outline Drawing (36 oz. cable tension only)

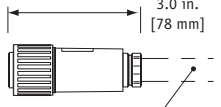

**A DIMENSION (INCHES)**

RANGE	MEASURING CABLE		
	Ø.034 in.	Ø.047 in.	Ø.062 in.
75	0.22	0.29	0.37
100	0.29	0.39	0.49
150	0.44	0.59	0.73
200	0.58	0.79	0.98
250	0.73	0.98	1.22
300	0.88	1.18	1.47
350	1.02	1.38	1.71
400	1.17	1.57	1.96
450	1.31	1.77	n/a
500	1.46	1.97	n/a
550	1.61	n/a	n/a

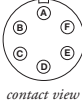
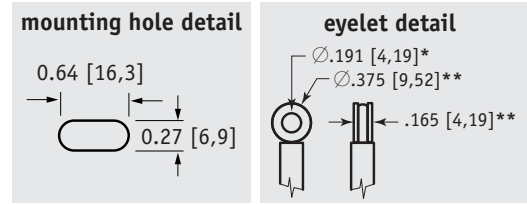
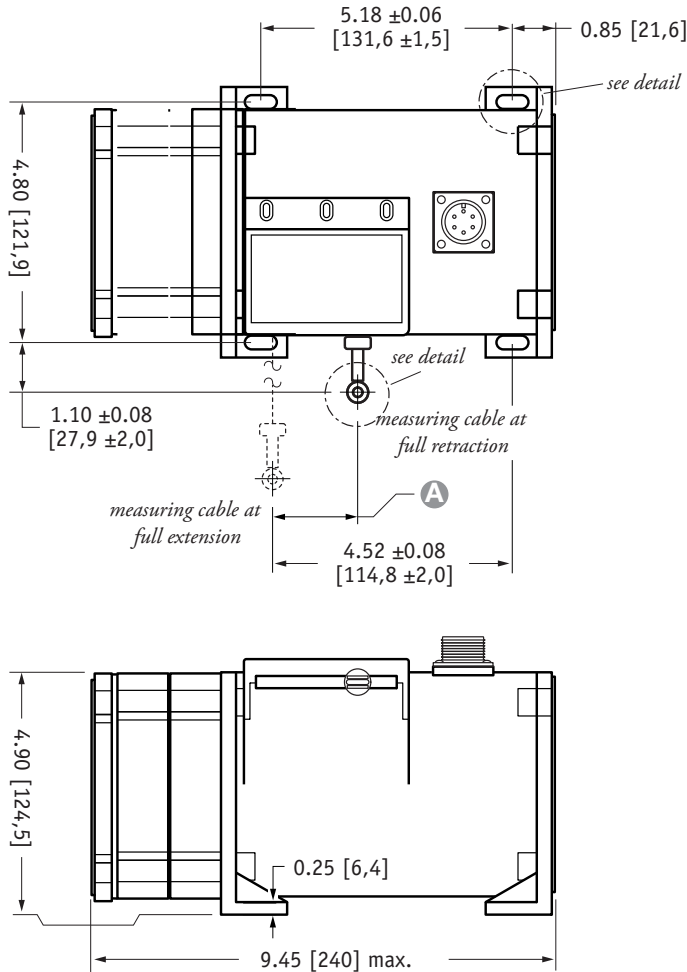
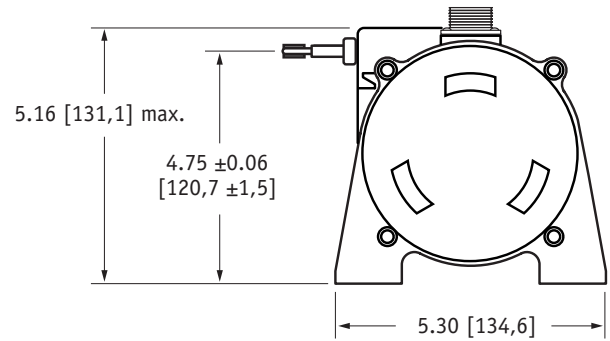

DIMENSIONS ARE IN INCHES [MM]  
tolerances are 0.03 IN. [0.5 MM] unless otherwise noted.

\* tolerance = +.005 -.001 [+13 -.03]  
\*\* tolerance = +.005 -.005 [+13 -.13]

## VLS Option - Free Release Protection

The patented Celesco Velocity Limiting System (VLS) is an option for PT9000 Series cable extension transducers that limits cable retraction to a safe 40 to 55 inches per second for the single spring option and 40 to 80 inches per second for the higher tension dual spring option.

The VLS option prevents the measuring cable from ever reaching a damaging velocity during an accidental free release. This option is ideal for mobile applications that require frequent cable disconnection and reconnection. It prevents expensive unscheduled downtime due to accidental cable mishandling or attachment failure.

How To Configure Model Number for VLS Option:

**VLS9232** -      -      -      -      -      -      -      -     

creating VLS model number (example)...

1. select PT9232 model **PT9232-0100-111-1110**
2. remove "PT" from the model number **~~PT~~ 9232-0100-111-1110**
3. add "VLS" **VLS + 9232-0100-111-1110**
4. completed model number ! **VLS9232-0100-111-1110**

version: 8.0 last updated: March 8, 2013

