

MT2A

Test Applications • Voltage Divider

Compact String Pot • Flight/Crash Test Applications

Dual Axis 360° Mounting Bracket

3, 9, 15, 30 and 50-inch Stroke Range Options

Aluminum & Polycarbonate Enclosure • GAM Certification

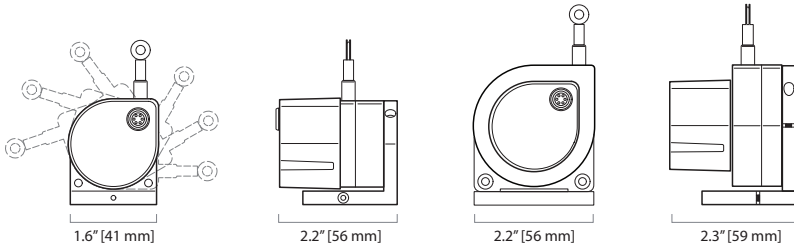

GENERAL

Full Stroke Range Options	0-3, 0-9, 0-15, 0-30, 0-50 inches, min.
Output Signal	voltage divider (potentiometer)
Accuracy	± 1.1% to 0.15% full stroke (see ordering information)
Repeatability	± 0.02% full stroke
Resolution	essentially infinite
Measuring Cable	Ø.019-in. nylon-coated stainless steel
Enclosure Material	anodized aluminum
Sensor Cover Options	aluminum or polycarbonate
Sensor	conductive plastic-hybrid potentiometer
Weight	0.5 lb. max.

ELECTRICAL

Input Resistance	10K ohms (± 10%)
Power Rating, Watts	2.0 at 158°F (70° C), derated to 0 @ 255°F (125°C)
Recommended Maximum Input Voltage	30V (AC or DC)
Electrical Stroke	94% ±4% of input voltage
Mating Plug	LEMO FGG.OB.304.CLAD52

MECHANICAL

Measuring Cable Tension Options	see ordering information
Maximum Measuring Cable Acceleration	136 g

ENVIRONMENTAL

Operating Temperature	-65° to 255° F (-55° to 125°C)
-----------------------	--------------------------------

GAM EG 13 CERTIFICATION

Specifications	see back page
----------------	---------------

20630 Plummer Street • Chatsworth, CA 91311 • Meas-Spec.com
tel: 800.423.5483 • +1.818.701.2750 • fax: +1.818.701.2799



0-3 to 0-30-inch version shown

The MT2A is a member of our family of rugged, accurate miniature cable-extension position transducers designed specifically for test applications. One of the major benefits to this sensor is its 2-axis 360° rotating mounting bracket to allow for fast and simple installation in any direction.

The MT2A comes in 5 different measuring ranges: 0-3", 0-9", 0-15", 0-30", 0-50" and features a highly-tensioned heavy-duty measuring cable designed for the high-acceleration demands encountered in flight testing and automotive crash tests.

For extreme impact applications, a new rugged all aluminum sensor cover is now available!

Output Signal

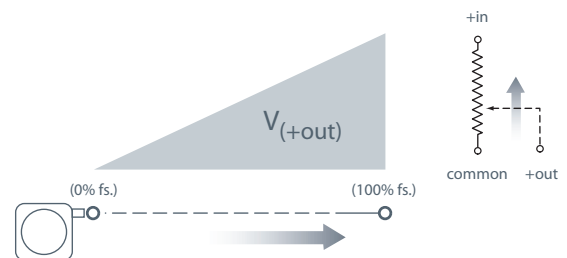

celesco.com • info@celesco.com
formally Celesco Transducer Products, Inc.

Outline Drawing (0-3 to 0-30-inch ranges):

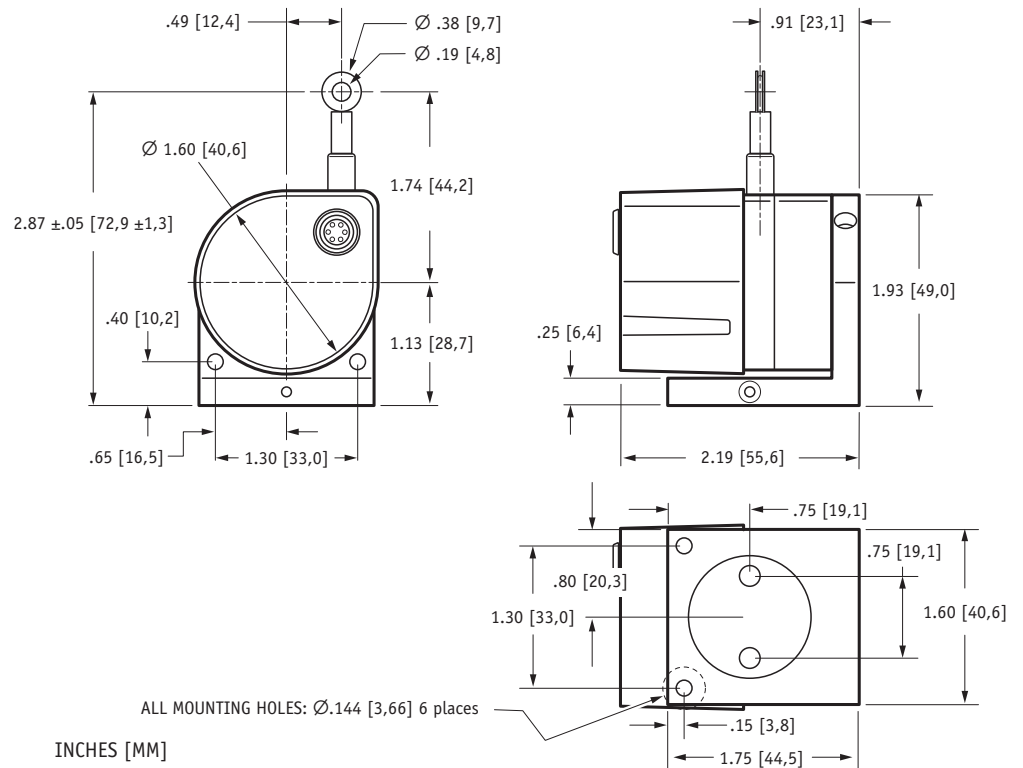

Outline Drawing (0-50-inch range):

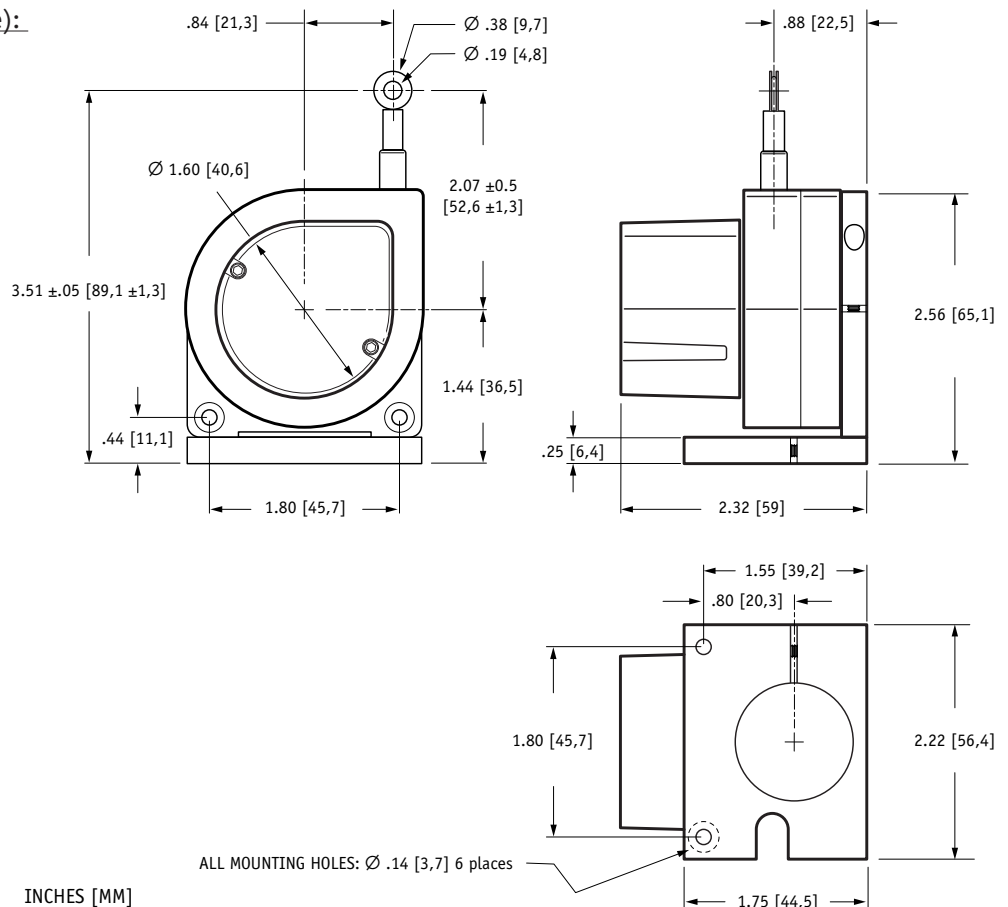

Ordering Information:

Model Number:

MT2A - - - **10K** -
order code: **R** **A** **B** **C**

Sample Model Number:

MT2A - 9E - 33 - 10K - M1A

R range: 9 inches
A measuring cable termination: eyelet
B measuring cable tension: 33 oz. (±6 oz.)
C electrical connection: end-mounted connector w/ aluminum sensor cover

Full Stroke Range:

R order code:	3	9	15	30	50
full stroke range, min:	3 inches	9 inches	15 inches	30 inches	50 inches
potentiometer cycle-life:	2.5×10^6	8.3×10^5	5.0×10^5	2.5×10^5	2.5×10^5
accuracy (% of full stroke):	1.1 %	.25%	.20%	.15%	.15%

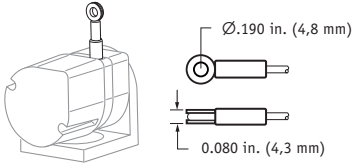
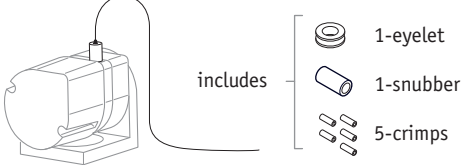

Measuring Cable Termination:



A order code:	E	L
	Eyelet	Leader Cable (24 in. long)
		
		includes: 1-eyelet, 1-snobber, 5-crimps

Measuring Cable Tension:

B order code:	9	14	33
3, 9, 15, 30-in. range options:	9 (±2) oz.	14 (±4) oz.	33 (±6) oz.
max. cable acceleration:	99 g	136 g	136 g
B order code:	9	22	
50-in. range options:	9 (±2) oz.	22 (±6) oz.	
max. cable acceleration:	46 g	68 g	

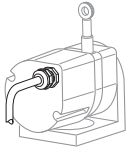
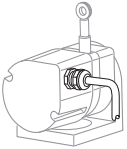
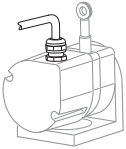
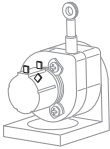
Electrical Connection/Sensor Cover:

G order code:	M1	M1A	M2	M2A	M3	M3A	
sensor cover:	polycarbonate	aluminum	polycarbonate	aluminum	polycarbonate	aluminum	
electrical connection:		end-mount connector*		side-mount connector*		top-mount connector*	
G order code:	C1	C1A	C2	C2A	C3	C3A	S
sensor cover:	polycarbonate	aluminum	polycarbonate	aluminum	polycarbonate	aluminum	none**
electrical connection:							
	end-mount, instrumentation cable (15-ft. long, 24 ga., shielded)		side-mount, instrumentation cable (15-ft. long, 24 ga., shielded)		top-mount, instrumentation cable (15-ft. long, 24 ga., shielded)		solder terminals

4-pin mating plug		Instrumentation Cable		Solder Terminals	
		pin#	signal	color	signal
contact view	Lemo FGG.0B.304.CLAD52	1	+in	Red	+in
		2	common	Black	common
		3	+out	Green	+out
					terminal
					CW
					CCW
					S

*mating plug included **blank cover available, see Accessories on next page

Accessories:

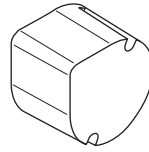
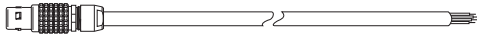

Additional blank sensor covers can be ordered separately. This cover comes without electrical wiring access holes so customer can drill to their requirements.

Includes screws and gasket.

Part Number	Description
9603957-0015	15 ft. long cordset. Includes mating connector with 15 ft., 24 gauge, shielded multiconductor cable

Part Number	Description
9604197-0000	Aluminum sensor cover
9603958-0000	Polycarbonate sensor cover

GAM EG 13 Certification (0-3 to 0-30 inch ranges only)

QUALIFICATION LEVEL FOR CLIMATIC AND THERMAL ENVIRONMENT

External Overpressure, operating (GAM EG 13 Fasc.21)

- 5 cycles: 1...4.5 Bar in 3 min., 4.5 Bar for 12 hours, 4.5...1 Bar in 1 min.
- 1 cycle: 1...3.2 Bar in 7.5 min., 3.2 Bar for 2 min., 3.2...8 Bar in 5 sec., 8 Bar for 2 hours, 8...1 Bar in 2 Bar/sec.
- 1 cycle: 1...4.5 Bar in 20 msec., 4.5 Bar for 5 sec, 4.5...1 Bar in 20 msec.

Thermal Vacuum Transitory, operating (GAM EG 13 Fasc.10)

- Room pressure and temperature (1 Bar A; 20°C ±2°C)
- 1...10-3 mBar in 100 seconds
- Vacuum (10-3 mBar) for 10 min.

Climatic Cycles (GAM EG 13 Fasc.8)

- Dry heat: 24 hours @ 70°C ±2°C Relative Humidity < 50%
- Wet heat: 24 hours @ 70°C ±2°C Relative Humidity = 50%
- Cold: 24 hours @ -10°C ±2°C Relative Humidity < 50%
- Wet heat: 24 hours @ 70°C ±2°C Relative Humidity = 100%

Dry Heat (Relative Humidity <50%)

- Room temperature to 70°C in 30 mins
- 70°C for 5 hours, non operating
- 70°C for 5 hours, operating
- 70°C to room temperature in 20 minutes

QUALIFICATION LEVEL FOR MECHANICAL ENVIRONMENT

Random Vibrations (GAM EG 13 Fasc.42 mod. Op1)

- 20...2000 Hz, 3 min. per axis, operating, 34 g.
- 20...2000 Hz, 20 sec. per axis, operating, 45 g.

Random Vibrations (GAM EG 13 Fasc.41 mod. Op3)

- Compensated Levels, short duration
- 3...300 Hz @ .2 – .002 g²/ Hz.

Research Critical Frequency

- Logarithmic Run, 1 octave / min., 1...2000 Hz.

Steady Acceleration, operating (GAM EG 13 Fas.45)

- 37 g, 3 min. per direction (2 directions per axis)

Sinusoidal Vibrations, operating (Gam EG 13 Fasc.41 mod. Op3)

- Logarithmic run, 1 octave/min. on 3 axis
- 3...50 Hz., 9 hours per axis @0.6...1.25 g

Sinusoidal Vibrations, operating (Gam EG 13 Fasc.41 mod. Op3)

- Logarithmic run, 1 octave/min. on 3 axis
- 5...2 KHz., 3 axis @12...25 g.

Average Shock (GAM EG 13 Fasc.43 Mode Op1)

- 1 shock, 1/2 sinusoidal, 100g., 6 msec. operating, wlongitudinal and back direction

Free Fall (GAM EG 13 Fasc.43 Mode Op4)

- 6 consecutive drops on wood table, height = 100mm



version: 8.0 last updated: November 16, 2015