

SR1H

Industrial • CANOpen Output Signal

Two Available Stroke Ranges: 0-125 in & 0-175 in.
 Rugged Polycarbonate Enclosure • Simple Installation
 Designed for Outdoor & IP67 environments
In Stock for Quick Delivery!

SPECIFICATIONS

Full Stroke Range, SR1H-125	125 inches (3175 mm), maximum
Full Stroke Range, SR1H-175	175 inches (4445 mm), maximum
Repeatability	.05% FS.
Resolution	12-bit
Input Voltage	10-36 VDC
Input Current	100 mA, max.
Maximum Velocity	80 inches (2 meters) per second
Maximum Acceleration	10 g (retraction)
Measuring Cable Tension	23 oz. (6.4 N) ±30%
Sensor	plastic-hybrid precision potentiometer
Cycle Life	250,000 (potentiometer)
Enclosure	polycarbonate
Measuring Cable	.031-inch dia. bare stainless rope
Electrical Connection	M12 Connector (mating plug included)
Environmental Suitability	NEMA 6, IP67
Operating Temperature	-40° to 185° F (-40° to 85° C)
Weight	2.5 lbs. (1.3 Kg)

CANopen SPECIFICATIONS

Communication Profile	CiA 301 V 4.0.2, CANopen Slave
Device Type	CiA 406 V3.2, Encoder
Vendor ID	Company x0002E0, Dept x00
Node ID	1-127 (Adjustable via dipswitch or LSS, default set to 1)
Baud Rate Options	125K (default), 250K, 500K, 1M
Data Rate	50ms (default)
Error Control	Heartbeat, Emergency Message
PDO	2 TxPDO, 0 RxPDO, no linking, static mapping
PDO Modes	Event / Time triggered, Synch / Asynch
SDO	1 server, 0 client
Position Data	Object Dictionary 6004
Cam Switches	Not Supported
EDS File**	http://celesco.com/support/software.htm

**-objects 1018, 1A03, 2002, and 6804 in EDS file are not supported

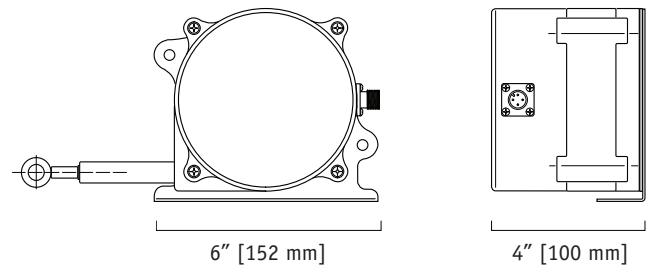

The SR1H is part of a series of rugged, low-cost, easy to install high performance string pots built for wet environments and outdoor applications.

The SR1H comes in two ranges: 0-125 inches and 0-175 inches and is the perfect low-cost CANOpen solution indoor factory environments or outdoor applications. Every unit ships with a handy mounting bracket giving the user the ultimate flexibility to easily orient the measuring cable to one of four different directions.

ORDERING INFORMATION

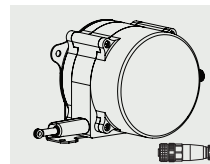

Order No.
SR1H-125
 125-inch stroke range, CANOpen communication, 5-pin M12 mating plug & mounting bracket included.

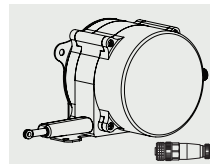

Order No.
SR1H-175
 175-inch stroke range, CANOpen communication, 5-pin M12 mating plug & mounting bracket included.

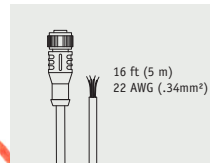

Order No.
9036810-0030
 for short-run connections, optional 16-ft (5 m) long cordset with 5-pin M12 mating plug.

20630 Plummer Street • Chatsworth, CA 91311 • Meas-Spec.com
 tel: 800.423.5483 • +1.818.701.2750 • fax: +1.818.701.2799



formally Celesco Transducer Products, Inc.
celesco.com • info@celesco.com

Position Data Overview

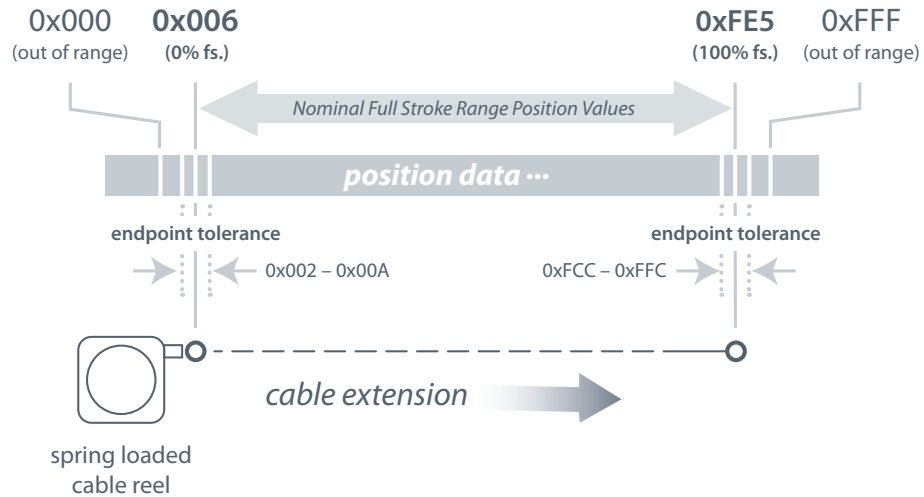

Electrical Connection

output signal	connector pin	colorcode (cordset)
drain	1	brown
10...36 VDC	2	white
common	3	blue
CAN high	4	black
CAN low	5	green/yellow

M12 Connector (included)

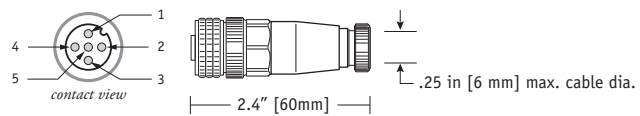

16 ft. Cordset (optional)

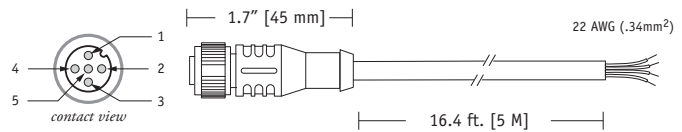

Internal Controller Board

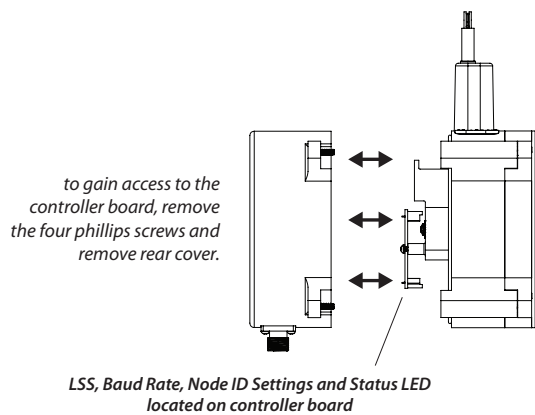

LSS, Baud Rate and Node ID settings:

LSS, Baud Rate and Node ID settings are set via dip switch found on the internal controller board. To gain access to the controller board, remove the 4 cover attaching screws and carefully separate the sensor cover from the main body.

Follow the instructions on the following pages for desired settings and reinstall sensor cover.

Status LED - Indicates Operating Condition of the Potentiometer		
green	red	
on	flash	emergency message (high)
off	flash	buffer (high)
on	off	normal operating range
flash	off	buffer (low)
flash	on	emergency message (low)

Settings:

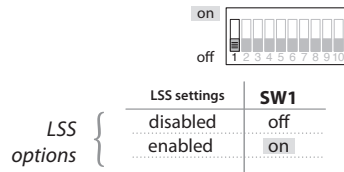

LSS Settings:

If DIP Switch 1 is set to “on” position, then LSS will be functional and uses the contents of EEPROM including Node ID and Baud Rate. If DIP Switch 1 is set to “off” position, then DIP switches will override information in EEPROM including the Node ID and Baud Rate.

BAUD Rate:

If DIP Switch 1 is set to “off” then BAUD rate is set via DIP switch 2 and 3 as shown :

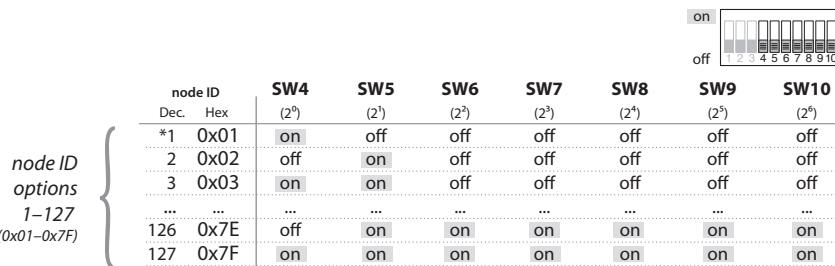
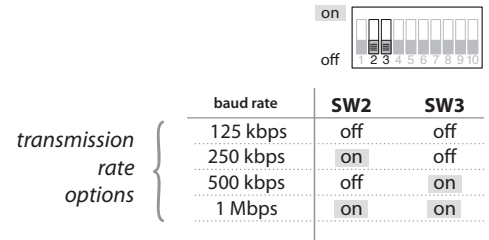

*note: Node ID=1 can also be set with ALL switches (SW4 – SW10) in the “off” position

Node ID:

If DIP Switch 1 is set to “off” then the Node ID is set via DIP switches 4 – 10 as shown below. The DIP switch settings are binary starting with switch number 4 (=2⁰) and ending with switch number 10 (=2⁶).

The Node ID is equal to the binary setting.

Manufacturer Objects:

Index	Sub-Index	Name	Default	Comment
2000		Raw Position Value		This is the averaged, non-scaled value from the encoder.
2001		Emergency Buffer Distance	0.1	Emergency Message is sent when the output of the sensing potentiometer is outside it’s calibrated range by more than .1% of the sensors full measurement range (Emergency Buffer). This allows for non-repeatability of sensor and customers application. This object allows user ability to change buffer size along with transmission of Emergency Message, Manufacturer specific bit in error register set, and error added to error list.

Device Profile Area:

Index	Sub-Index	Name	Default	Comment
6000		Operating Parameters	0X0000	
6004		Position Value		Counts proportional to measuring cable extension. Nominal values are 0x006 with cable fully retracted and 0xFE5 with cable fully extended. Format of data in CAN message is little endian – least significant byte pair first. Therefore 0x008 would be shown as “08 00” and 0xFE5 would be shown as “E5 0F”
6400		Area State Register		SubNumber= 2 (indicates underflow or overflow per CiA406)
	0	Highest Subindex	0x01	
	1	Work Area State Channel 1	0	

Device Profile Area (cont.):

Index	Sub-Index	Name	Default	Comment
6401		Work Area Low Limit		The averaged, non-scaled (raw) encoder data below which the encoder is out of range.
	0	Highest Subindex	0x01	
	1	Work Area Low Limit Channel1	0x024	
6402		Work Area High Limit		The averaged, non-scaled (raw) encoder data above which the encoder is out of range.
	0	Highest Subindex	0x01	
	1	Work Area High Limit Channel 1	0xF4E	
6500		Operating Status	0x0000	
6501		Measuring Step	1	Position Measuring Step. Can be set by user to convert Position Value (Object 6004) to measurement units (inches, mm). Default is set to 1.

Communication Area Profile:

Index	Sub-Index	Name	Default	Comment
1000		Device Type	0X00080196	Device Profile 406
1001		Error Register	0	Manufacturer Specific Error bit 7 is set when sensor is outside of calibrated range and cleared when back in range.
1003		Pre-Defined Error Field		SubNumber= 9 (lists last eight Emergency Messages)
	0	Number of Errors	0	
	1	Standard Error Field 1		
	2	Standard Error Field 2		
	3	Standard Error Field 3		
	4	Standard Error Field 4		
	5	Standard Error Field 5		
	6	Standard Error Field 6		
	7	Standard Error Field 7		
	8	Standard Error Field 8		
1005		SYNC COB-ID	0x80	
1010		Store Parameters		SubNumber=2
1010	0	Highest Subindex	0x01	Only "Save All Parameters" feature supported
	1	Save All Parameters		Write "save" or "evsa" to save parameters to EEPROM. They are automatically loaded on power up/reset. Saves the value of all R/W object dictionary entries.
1014		Emergency COB-ID	\$NodeID + 0x80	COB-ID Emergency Message
1015		Emergency Inhibit Time	0	Multiple of 100µs. Minimum time between transmissions of emergency messages.
1017		Producer Heartbeat Time	0	Multiples of 1 ms. Time between transmission of heartbeat messages. 0 = disabled

Communication Area Profile (cont.):

Index	Sub-Index	Name	Default	Comment
1018		Identity Object		
	0	Number of Entries	4	
	1	Vendor Id	0x2E0	
	2	Product Code	269 (decimal)	Celesco Reference #604269
	3	Revision Number	2	
	4	Serial Number	0x00000000	
1800		Tx PDO Comm. Parameter		PDO1
	0	Number of Entries	5	
	1	COB-ID	\$NodeID + 0x108	COB-ID used by PDO1
	2	Transmission Type	254 (decimal)	PDO1 Tx Type: 0 = on Sync Message. 254 = Asynchronous Tx
	3	Inhibit Time	0	Multiple of 100µs. Minimum time between transmissions of the PDO
	5	Event Timer	0x32	If non-zero then transmits the PDO periodically. This value is a multiple of 1ms.
1801		Tx PDO Comm. Parameter		PDO2
	0	Number of Entries	5	
	1	COB-ID	\$NodeID + 0x280	COB-ID used by PDO2
	2	Transmission Type	0x01	PDO2 Tx Type: 0 = on Sync Message. 254 = Asynchronous Tx
	3	Inhibit Time	0	Multiple of 100µs. Minimum time between transmissions of the PDO
	5	Event Timer	0	If non-zero then transmits the PDO periodically. This value is a multiple of 1ms.
1A00		Tx PDO Mapping Parameter		Subnumber = 2
	0	Number of Entries	1	
	1	PDO Mapping Entry	0x60040020	Mapping Parameter
1A01		Tx PDO Mapping Parameter		Subnumber = 2
	0	Number of Entries	1	
	1	PDO Mapping Entry	0x60040020	Mapping Parameter

Changing the Cable Exit

Changing Measuring Cable Exit

To change the direction of the measuring cable, remove the 4 mounting bracket screws and rotate bracket to one of four available positions. See figures 1 - 4 on the following pages for mounting dimensions.

Changing Electrical Connector Direction

To change the position of the electrical connector, remove the 4 rear cover screws and carefully separate rear cover from the sensor body.

Rotate the rear cover to desired position being careful to not tangle the wiring harness that runs to the connector.

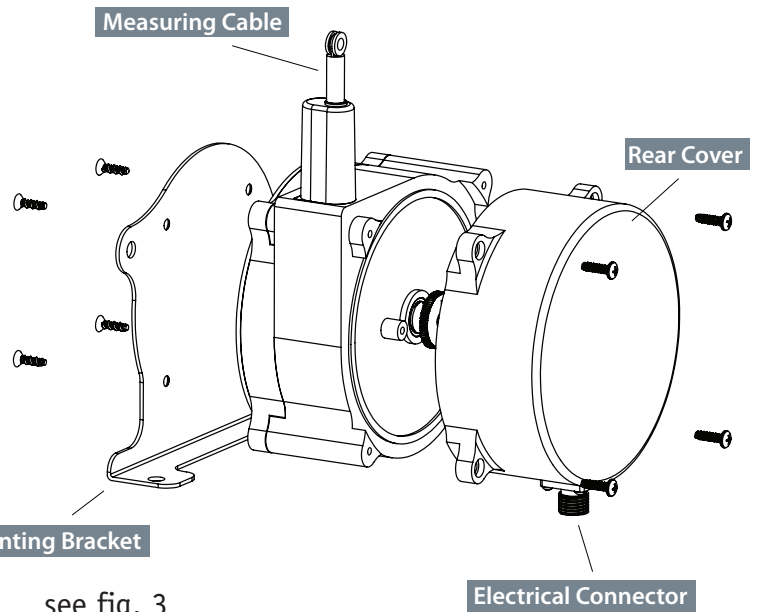

Cable Exit Direction Options

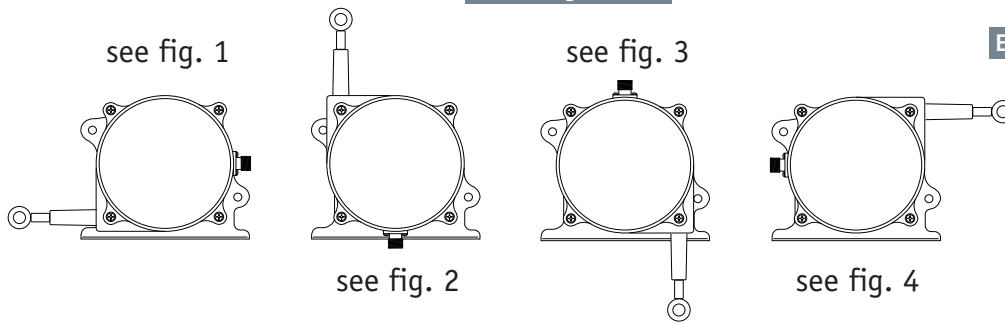
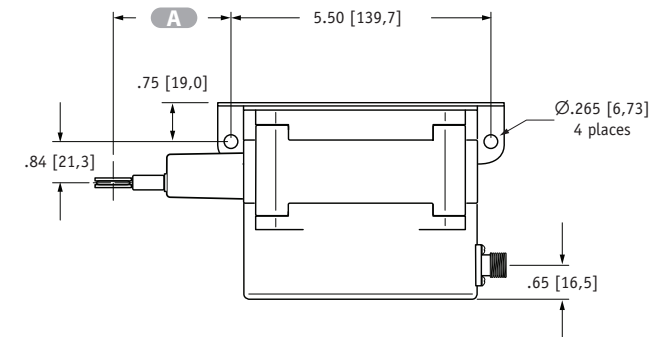
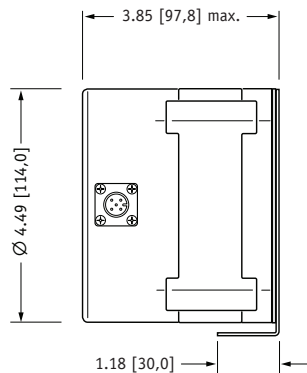
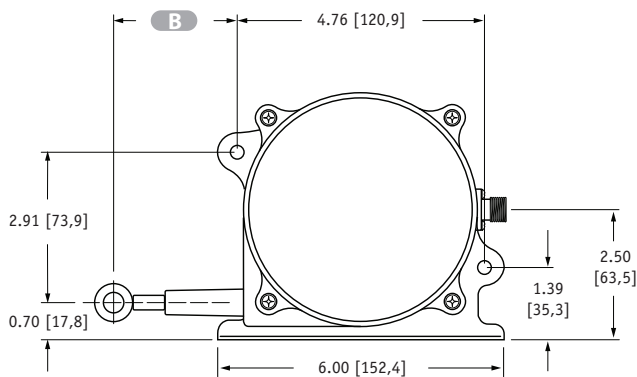
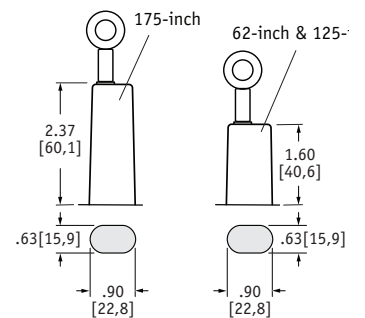

Fig. 1 - Outline Drawing (as shipped)



Model	A	B
125-inch	2.00 ±.13 [50,8 ±3,3]	2.37 ±.13 [60,22 ±3,3]
175-inch	2.87 ±.13 [72,8 ±3,2]	3.24 ±.13 [82,2 ±3,2]

Cable Guide Detail



Eyelet Detail

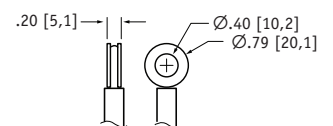

units are in inches [mm] tolerances are ± .04 [1,0] unless otherwise noted

Fig. 2 - "Up" Cable Exit Direction

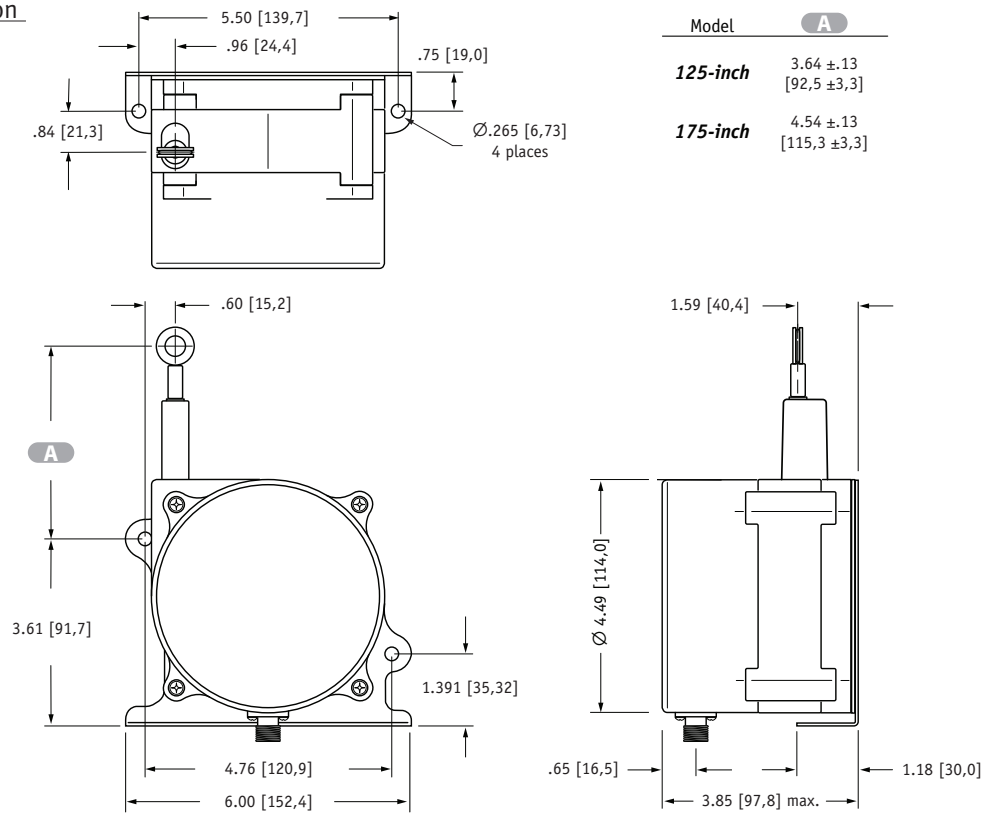

Fig. 3 - "Down" Cable Exit Direction

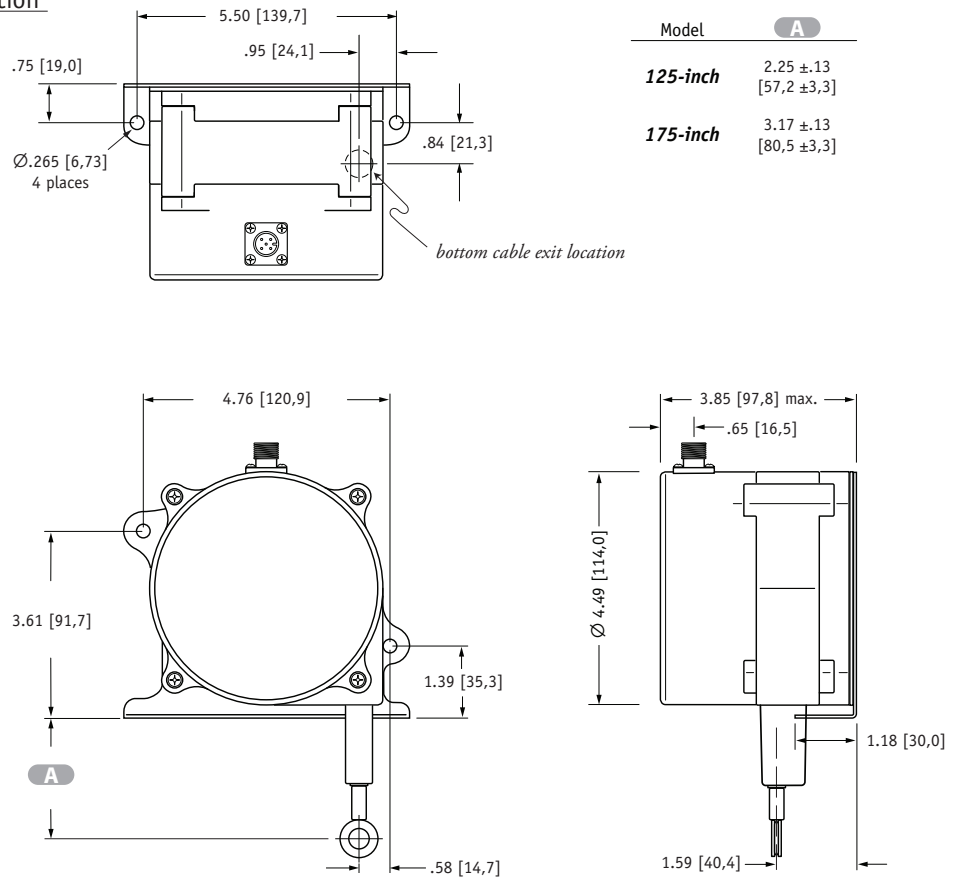
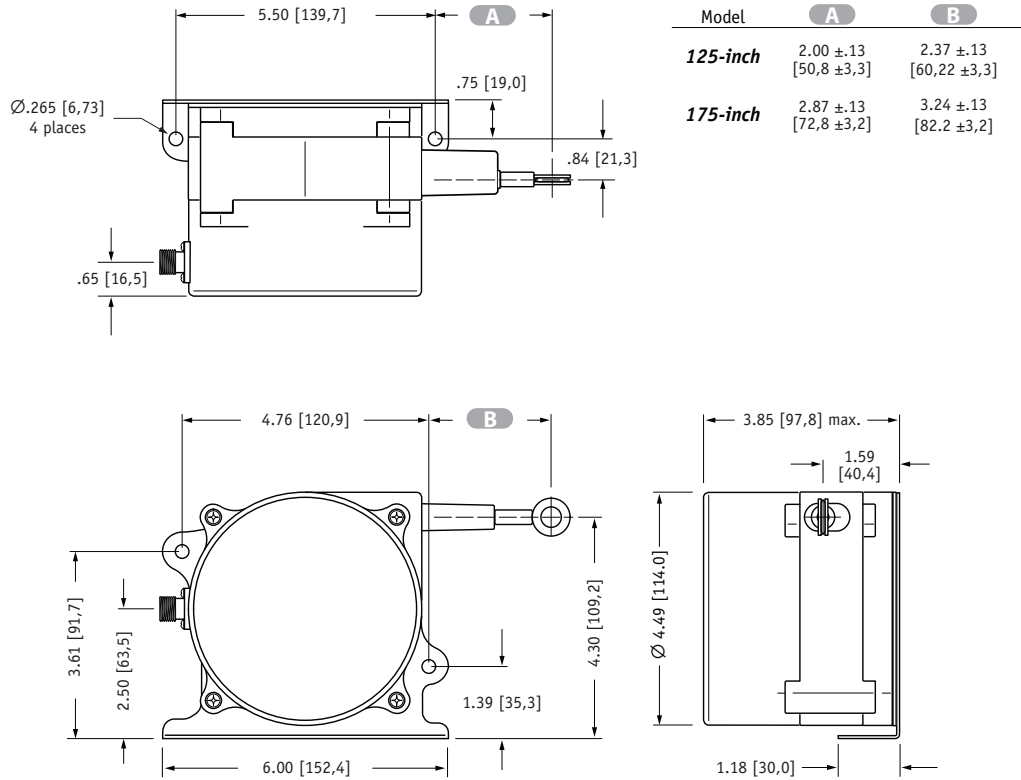

Fig. 4 - "Rear" Cable Exit Direction



units are in inches [mm] tolerances are ± .04 [1,0] unless otherwise noted



version: 1.0 last updated: June 15, 2016