

SKH

CANOpen Output Signal

Linear Position to 400 inches (10 m)
 Compact Design • Simple To Install
 User Adjustable Measuring Cable Orientation
IN STOCK for Quick Delivery!

SPECIFICATIONS

Stroke Range Options	250 inches (6.4 m), 400 inches (10.2 m)
Accuracy	.35% FS.
Repeatability	.05% FS.
Resolution	12-bit
Input Voltage	10-36 VDC
Input Current	100 mA, max.
Measuring Cable	.031-inch dia. bare stainless steel
Maximum Cable Velocity	60 inches per second
Maximum Cable Acceleration	5 g
Measuring Cable Tension	23 oz. (6.4 N) ±40%
Sensor	plastic-hybrid precision potentiometer
Cycle Life	≥ 250,000
Electrical Connection	M12 connector, mating plug included
Enclosure	glass-filled polycarbonate
Environmental	IP67
Operating Temperature	-40° to 185° F (-40° to 85° C)

CANopen SPECIFICATIONS

Communication Profile	CiA 301 V 4.0.2, CANopen Slave
Device Type	CiA 406 V3.2, Encoder
Vendor ID	0x0002E0, Node ID
1-127 (Adjustable via dipswitch or LSS, default set to 1)	
Baud Rate Options	125K (default), 250K, 500K, 1M
Data Rate	50ms (default)
Error Control	Heartbeat, Emergency Message
PDO	2 TxPDO, 0 RxPDO, no linking, static mapping
PDO Modes	Event / Time triggered, Synch / Asynch
SDO	1 server, 0 client
Position Data	Object Dictionary 6004
Cam Switches	Not Supported

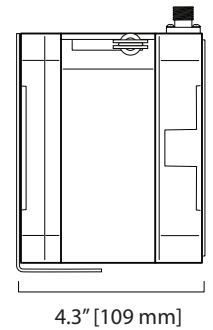
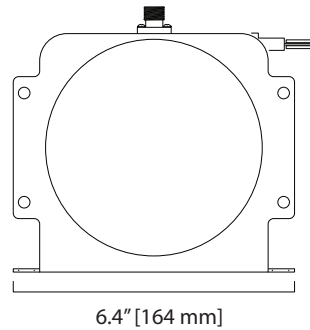
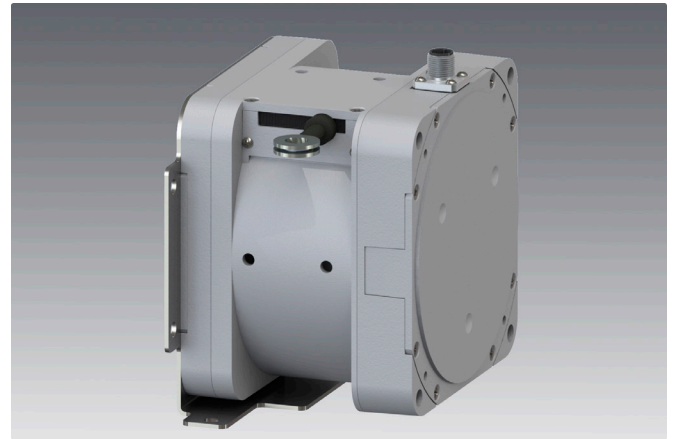

The SKH has a CANopen output signal that delivers linear position feedback for applications ranging from outrigger position on a mobile crane to tracking the height of a hydraulic lift table in a factory and everything else in between. Available in both 250 and 400-inch stroke ranges, this model offers the ultimate ease-of-use, compact design and user flexibility. Need to mount it upside down? Simply rotate its stainless mounting bracket to where you want it. Need the electrical connector to point in a different direction? Just rotate the rear cover to point the connector to the desired direction.

It's compact design, ease of use and the utmost in flexibility makes this model the perfect economically priced solution for both the single piece user to the higher volume OEM.

Output Signal

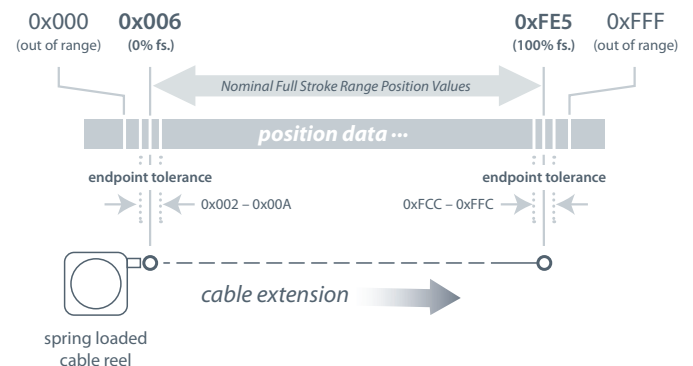

Outline Drawing:

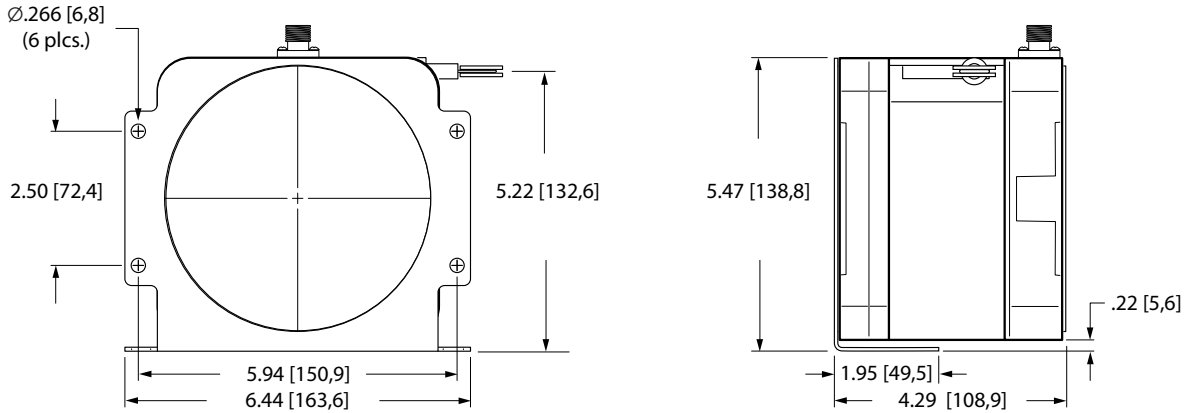
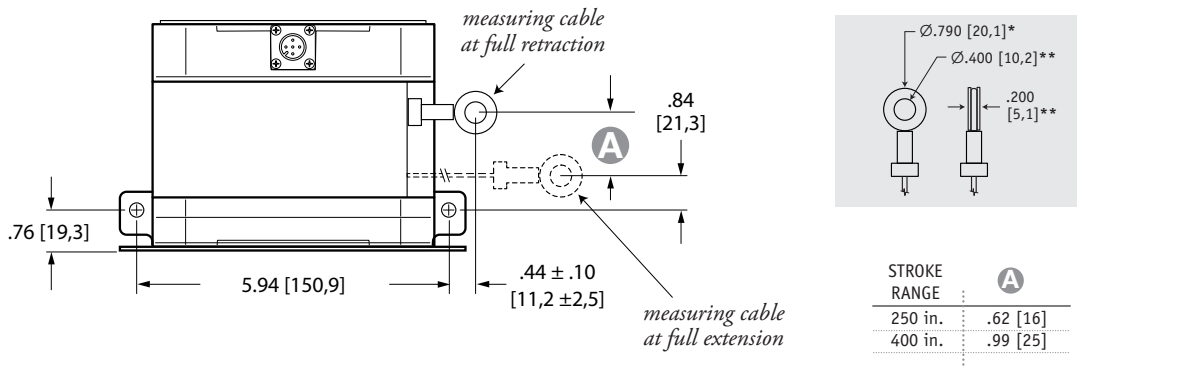

DIMENSIONS ARE IN INCHES [MM]
tolerances are 0.04 IN. (1.0 MM) unless otherwise noted.

* tolerance = +.005 - .001 [+0,1 - 0,0]
** tolerance = +.005 - .005 [+0,1 - 0,1]

Mounting Options:

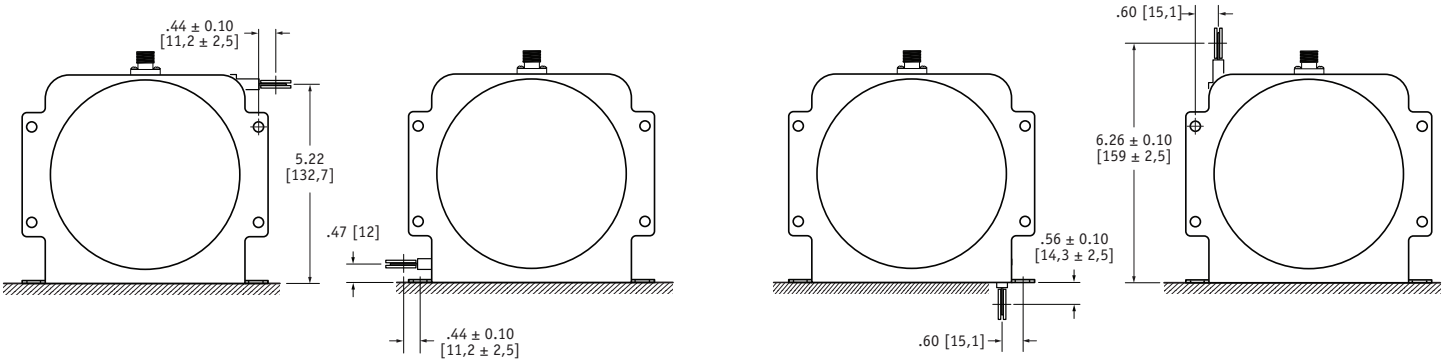

To change cable exit direction: simply remove the 4 bracket mounting screws and rotate sensor body to desired direction.

To change electrical connector orientation: remove the 4 rear screws and carefully remove the rear cover and rotate cover.

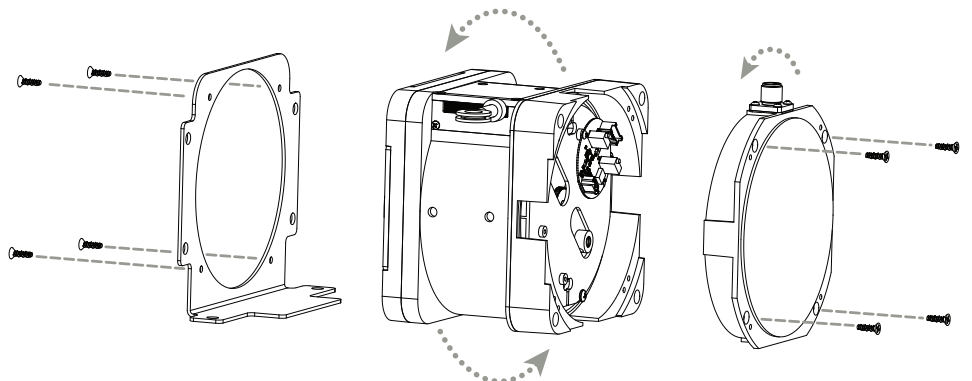

Ordering Information:

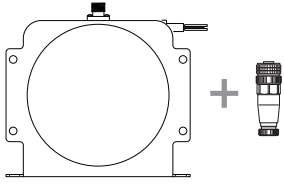

Part Number	full stroke range	accuracy	max. acceleration	measuring cable tension (± 40%)
SKH-250-4	250 in (6.4 m)	.35%	5 g	23 oz. (6,4 N)
SKH-400-4	400 in (10.2 m)	.35%	5 g	23 oz. (6,4N)

includes mounting bracket & mating connector.

Optional Cordsets

Part Number

length wire size connector

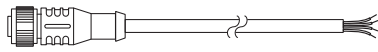

9036810-0030

13 ft (4 m) 22 AWG (.34mm²)

straight 5-pin M12



9036810-0031

13 ft (4 m) 22 AWG (.34mm²)

90° 5-pin M12

Electrical Connection:

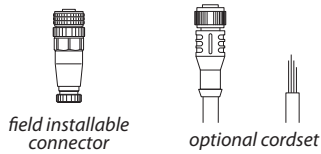

Output Signal

Output Signal	pin	pin - color
• drain	1	1 - brown
10..36 Vdc	2	2 - white
common	3	3 - blue
CAN - High	4	4 - black
CAN - Low	5	5 - green/yellow

Field Installable Connector:

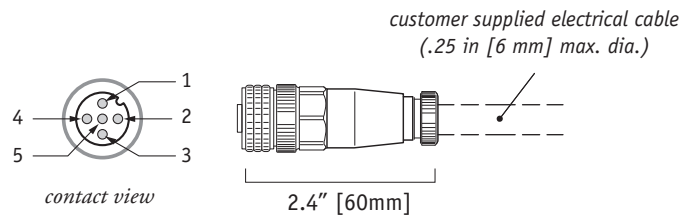

Position Data Overview:

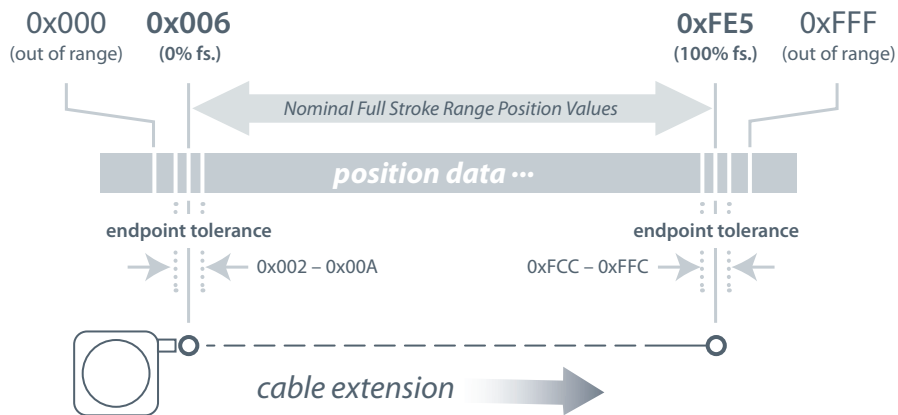

Internal Controller Board

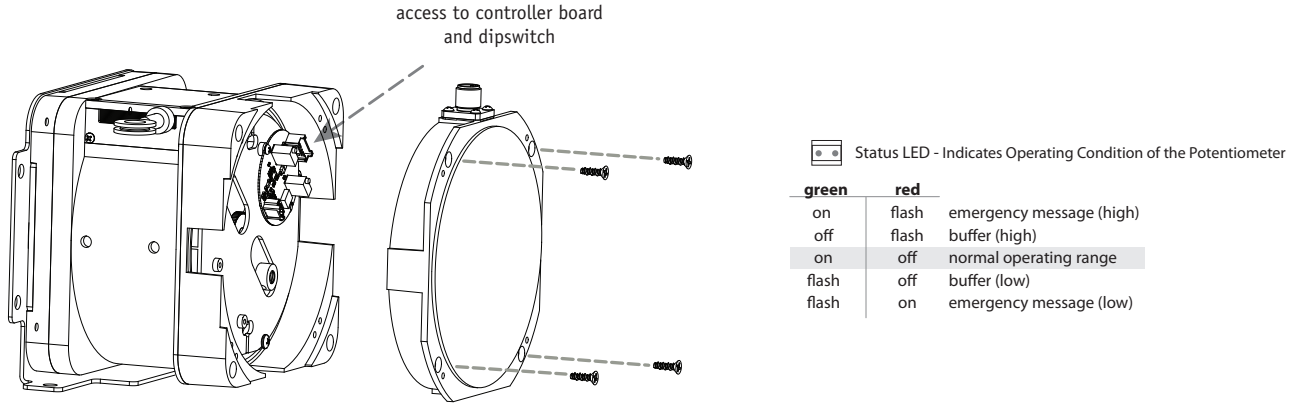

LSS, Baud Rate and Node ID settings:

LSS, Baud Rate and Node ID settings are set via dip switch found on the internal controller board. To gain access to the controller board, remove the 4 cover attaching screws and carefully separate the sensor cover from the main body. Be careful not to damage the small gage wires that connect the potentiometer to the controller board mounted directly to the rear cover.

Follow the instructions below for desired settings and reinstall sensor cover.

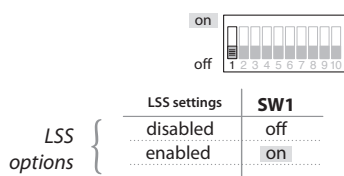

LSS Settings:

IF DIP Switch 1 is set to "on" position, then LSS will be functional and uses the contents of EEPROM including Node ID and Baud Rate. If DIP Switch 1 is set to "off" position, then DIP switches will override information in EEPROM including the Node ID and Baud Rate.

BAUD Rate:

If DIP Switch 1 is set to "off" then BAUD rate is set via DIP switch 2 and 3 as shown:

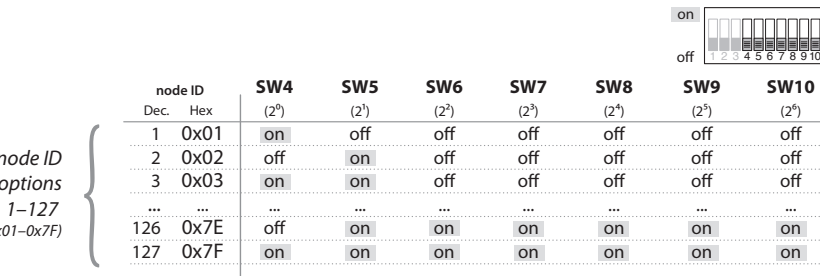
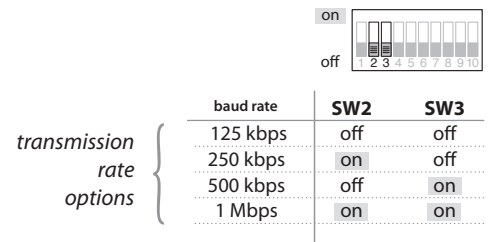

Node ID:

If DIP Switch 1 is set to "off" then the Node ID is set via DIP switches 4 – 10 as shown below. The DIP switch settings are binary starting with switch number 4 (=2⁰) and ending with switch number 10 (=2⁶).

The Node ID is equal to the binary setting.

Manufacturer Objects:

Index	Sub-Index	Name	Default	Comment
2000		Raw Position Value		This is the averaged, non-scaled value from the encoder.
2001		Emergency Buffer Distance	0.1	Emergency Message is sent when the output of the sensing potentiometer is outside it's calibrated range by more than .1% of the sensors full measurement range (Emergency Buffer). This allows for non-repeatability of sensor and customers application. This object allows user ability to change buffer size along with transmission of Emergency Message, Manufacturer specific bit in error register set, and error added to error list.

Device Profile Area:

Index	Sub-Index	Name	Default	Comment
6000		Operating Parameters	0X0000	
6004		Position Value	0	Counts proportional to measuring cable extension. Nominal values are 0x006 with cable fully retracted and 0xFE5 with cable fully extended. Format of data in CAN message is little endian – least significant byte pair first. Therefore 0x008 would be shown as "08 00" and 0xFE5 would be shown as "E5 0F"
6400		Area State Register		SubNumber= 2 (indicates underflow or overflow per CiA406)
	0	Highest Subindex	0x01	
	1	Work Area State Channel 1	0	
6401		Work Area Low Limit		The averaged, non-scaled (raw) encoder data below which the encoder is out of range.
	0	Highest Subindex	0x01	
	1	Work Area Low Limit Channel1	0x024	
6402		Work Area High Limit		The averaged, non-scaled (raw) encoder data above which the encoder is out of range.
	0	Highest Subindex	0x01	
	1	Work Area High Limit Channel 1	0xF4E	
6500		Operating Status	0x0000	
6501		Measuring Step	1	Position Measuring Step. Can be set by user to convert Position Value (Object 6004) to measurement units (inches, mm). Default is set to 1.

Communication Area Profile:

Index	Sub-Index	Name	Default	Comment
1000		Device Type	0X00080196	Device Profile 406
1001		Error Register	0	Manufacturer Specific Error bit 7 is set when sensor is outside of calibrated range and cleared when back in range.
1003		Pre-Defined Error Field		SubNumber= 9 (lists last eight Emergency Messages)
	0	Number of Errors	0	
	1	Standard Error Field 1		
	2	Standard Error Field 2		
	3	Standard Error Field 3		
	4	Standard Error Field 4		
	5	Standard Error Field 5		
	6	Standard Error Field 6		
	7	Standard Error Field 7		
	8	Standard Error Field 8		
1005		SYNC COB-ID	0x80	
1010		Store Parameters		SubNumber=2
1010	0	Highest Subindex	0x01	Only "Save All Parameters" feature supported
	1	Save All Parameters		Write "save" or "evsa" to save parameters to EEPROM. They are automatically loaded on power up/reset. Saves the value of all R/W object dictionary entries.
1014		Emergency COB-ID	\$NodeID + 0x80	COB-ID Emergency Message
1015		Emergency Inhibit Time	0	Multiple of 100us. Minimum time between transmissions of emergency messages.
1017		Producer Heartbeat Time	0	Multiples of 1ms. Time between transmission of heartbeat messages. 0 = disabled
1018		Identity Object		
	0	Number of Entries	4	
	1	Vendor Id	0x2E0	
	2	Product Code	0x10D	Celesco Reference # 604269
	3	Revision Number	0x1	
	4	Serial Number	0xFFFFFFFF	
1800		Tx PDO Comm. Parameter		PDO1
	0	Number of Entries	5	
	1	COB-ID	\$NodeID + 0x108	COB-ID used by PDO1
	2	Transmission Type	254	PDO1 Tx Type: 0 = on Sync Message. 254 = Asynchronous Tx
	3	Inhibit Time	0	Multiple of 100us. Minimum time between transmissions of the PDO
	5	Event Timer	0x32	If non-zero then transmits the PDO periodically. This value is a multiple of 1ms.

Communication Area Profile (cont.):

1801		Tx PDO Comm. Parameter		PDO2
	0	Number of Entries	5	
	1	COB-ID	\$NodeID + 0x280	COB-ID used by PDO2
	2	Transmission Type	0	PDO2 Tx Type: 0 = on Sync Message. 254 = Asynchronous Tx
	3	Inhibit Time	0	Multiple of 100us. Minimum time between transmissions of the PDO
	5	Event Timer	0	If non-zero then transmits the PDO periodically. This value is a multiple of 1ms.
1A00		Tx PDO Mapping Parameter		Subnumber = 2
	0	Number of Entries	1	
	1	PDO Mapping Entry	0x60040020	Mapping Parameter
1A01		Tx PDO Mapping Parameter		Subnumber = 2
	0	Number of Entries	1	
	1	PDO Mapping Entry	0x60040020	Mapping Parameter

Version: 2.0 last updated: February 2, 2016