

SR1J

Industrial • CANBus J1939

Two Available Stroke Ranges: 0-125 in & 0-175 in.
 Rugged Polycarbonate Enclosure • Simple Installation
 Designed for Outdoor & IP67 environments
In Stock for Quick Delivery!

SPECIFICATIONS

Full Stroke Range, SR1J-125	125 inches (3175 mm), maximum
Full Stroke Range, SR1J-175	175 inches (4445 mm), maximum
Repeatability	.05% FS.
Resolution	12-bit
Input Voltage	10-36 VDC
Input Current	100 mA, max.
Maximum Velocity	80 inches (2 meters) per second
Maximum Acceleration	10 g (retraction)
Measuring Cable Tension	23 oz. (6.4 N) ±30%
Sensor	plastic-hybrid precision potentiometer
Cycle Life	250,000 (potentiometer)
Enclosure	polycarbonate
Measuring Cable	.031-inch dia. bare stainless rope
Electrical Connection	M12 Connector (mating plug included)
Environmental Suitability	NEMA 6, IP67
Operating Temperature	-40° to 185° F (-40° to 85° C)
Weight	2.5 lbs. (1.3 Kg)

CANopen SPECIFICATIONS

Communication Profile	CANbus SAE J1939
Protocol	Proprietary B
Node ID	Adjustable via dipswitch (0-63), default set to 0
Baud Rate Options	125K (default), 250K, 500K
Data Rate Options	5ms (default), 20ms, 50ms, 100ms

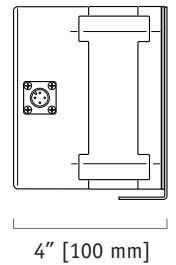
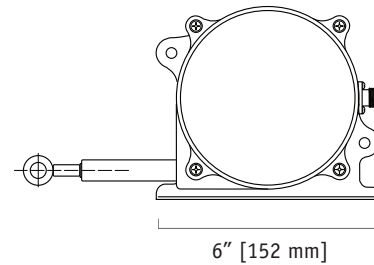

The SR1J is a rugged, low-cost, easy to install high performance string pots built for wet environments and outdoor applications.

The SR1J comes in two ranges: 0-125 inches and 0-175 inches and is the perfect low-cost J1939 CANbus solution for mobile applications such as mobile crane outrigger position or hydraulic lifts. Every unit ships with a handy mounting bracket giving the user the ultimate flexibility to easily orient the measuring cable to one of four different directions.

ORDERING INFORMATION

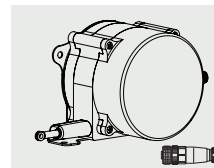

Order No.

SR1J-125

125-inch stroke range, CANBus J1939 communication, 5-pin M12 mating plug & mounting bracket included.

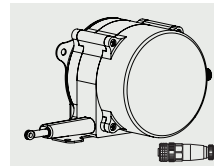

Order No.

SR1J-175

175-inch stroke range, CANBus J1939 communication, 5-pin M12 mating plug & mounting bracket included.

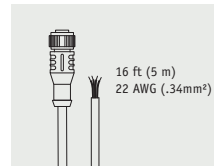

Order No.

9036810-0030

for short-run connections, optional 16-ft (5 m) long cordset with 5-pin M12 mating plug.

Electrical Connection

output signal	connector pin	colorcode (cordset)
drain	1	brown
10...36 VDC	2	white
common	3	blue
CAN high	4	black
CAN low	5	green/yellow

M12 Connector (included)

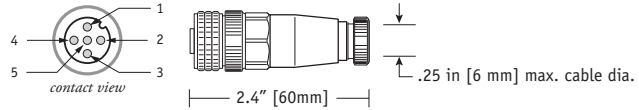

16 ft. Cordset (optional)

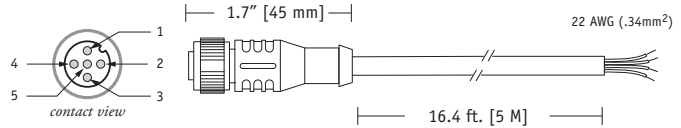

Internal Controller Board

LSS, Baud Rate and Node ID settings:

LSS, Baud Rate and Node ID settings are set via dip switch found on the internal controller board. To gain access to the controller board, remove the 4 cover attaching screws and carefully separate the sensor cover from the main body.

Follow the instructions on the following pages for desired settings and reinstall sensor cover.

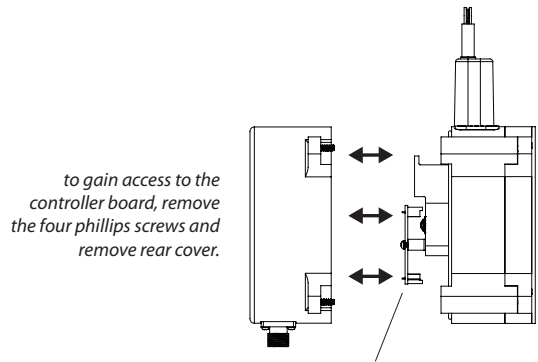

LSS, Baud Rate, Node ID Settings and Status LED located on controller board

Baud, Node ID and Data Rate:

Baud Rate, Node ID and Data Rate settings are set via dip switch found on the internal controller board. To gain access to the controller board, remove the 4 cover attaching screws and carefully separate the sensor cover from the main body. Be careful not to damage the small gage wires that connect the controller board to the connector mounted directly to the rear cover.

Follow the instructions below for desired settings and reinstall sensor cover.

node ID options 0-63 (0x00-0x3F)	node ID		SW1	SW2	SW3	SW4	SW5	SW6	BAUD rate options		
	Dec.	Hex	(2 ¹)	(2 ¹)	(2 ¹)	(2 ¹)	(2 ¹)	(2 ¹)	baud rate	SW7	SW8
0	0x00	off	off	off	off	off	off	off	125 kbps	off	off
1	0x01	on	off	off	off	off	off	off	250 kbps	on	off
2	0x02	off	on	off	off	off	off	off	500 kbps	off	on
3	0x03	on	on	off	off	off	off	off			
...			
62	0x3E	off	on	on	on	on	on	on			
63	0x3F	on	on	on	on	on	on	on			

Data Rate options	Data Rate		SW9	SW10
	Data Rate		SW9	SW10
5 ms	5 ms	off	off	
20 ms	20 ms	on	off	
50 ms	50 ms	off	on	
100 ms	100 ms	on	on	

I/O Format:

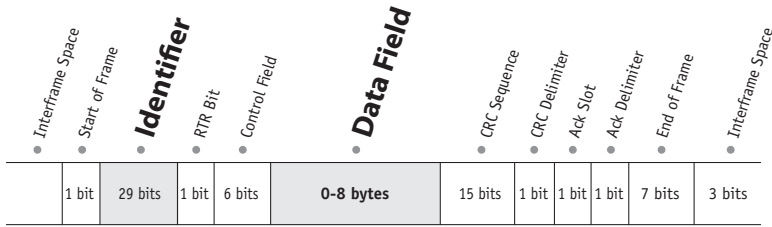

Position Data Overview

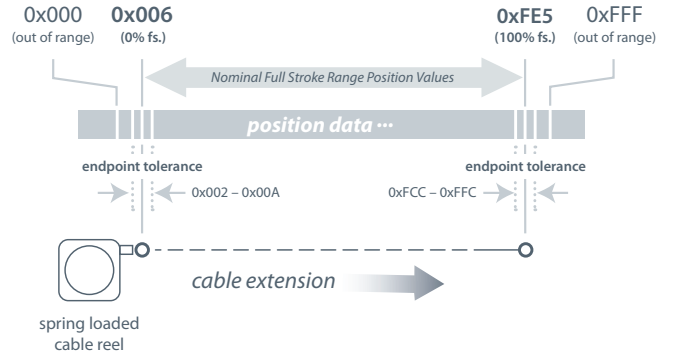

Identifier:

	Message Priority	Future Use	J1939 Reference Proprietary B												Data Field Type*				Not Used		Node ID**								
Example -	1	0	0	0	0	1	1	1	1	1	1	1	1	0	1	0	1	0	0	1	1	0	0	1	1	1	1	1	1
Identifier Bit No. -	28	27	26	25	24	23	22	21	20	19	18	17	16	15	14	13	12	11	10	9	8	7	6	5	4	3	2	1	0
Hex Value -	0				F				F				5				3				3		F						

*Sensor field data can be factory set to customer specific value. **Customer defined, set via Dips 1-6. Bit values shown for example only, see Address Setting below.

Data Field:

- B₀ = LSB current measurement count byte
- B₁ = MSB current measurement count byte
- B₂ = not used
- B₃ = not used

- B₄ = error flag
- B₅ = error flag
- B₆ = LSB velocity data byte
- B₇ = MSB velocity data byte

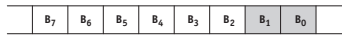
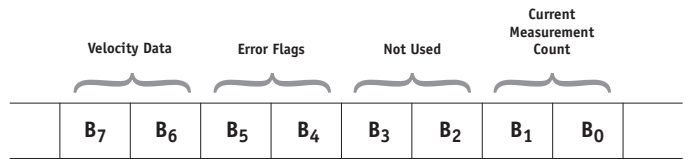

Current Measurement Count

The **Current Measurement Count (CMC)** is the output data that indicates the present position of the measuring cable. The CMC is a 12-bit value that occupies bytes **B₀** and **B₁** of the data field. **B₀** is the **LSB** (least significant byte) and **B₁** is the **MSB** (most significant byte).

The **CMC** starts at **0x006** with the measuring cable fully retracted and continues upward to the end of the stroke range stopping at **0xFE5**. This holds true for all ranges.

Error Flags

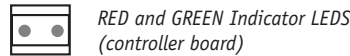

0x00 (GREEN - ON, RED - OFF) indicates the sensor is operating within normal calibrated limits.

0x33, 0x55, 0xAA, 0xCC (RED or GREEN - FLASHING) indicates sensor is at or beyond its calibrated measurement range. Should any of these conditions occur within calibrated range, return unit to factory for evaluation or service.

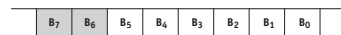

Velocity

Data in bytes **B₇** - **B₆** is the change in the **CMC** (current measurement count) over a 100 msec time period. This data can then be used to calculate velocity in a post processing operation.

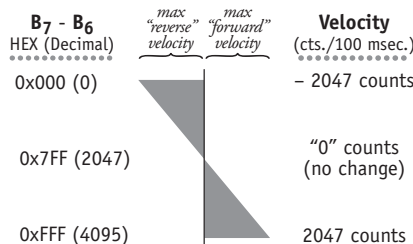

Velocity Calculation

$$\left(\frac{\text{count change} - 2047}{.1 \text{ sec. time period}} \right) \times \left(\frac{\text{full stroke range}}{4063} \right)$$

Sample Calculations

Cable Extension (positive direction):

B₇..B₆ = 0x8D3 (2259Dec), full stroke = 250 in.

$$\left(\frac{2259 - 2047}{.1 \text{ sec}} \right) \times \left(\frac{250 \text{ in.}}{4063} \right) = 130.45 \text{ in. / sec.}$$

Cable Retraction (negative direction):

B₇..B₆ = 0x7D0 (2000Dec), full stroke = 250 in.

$$\left(\frac{2000 - 2047}{.1 \text{ sec}} \right) \times \left(\frac{250 \text{ in.}}{4063} \right) = -28.92 \text{ in. / sec.}$$

Converting CMC to Linear Measurement

To convert the current measurement count to inches or millimeters, simply divide the count by 4061 (total counts over the range) and then multiply that value by the full stroke range:

$$\left(\frac{\text{CMC} - 6}{4063} \right) \times \text{full stroke range}$$

Sample Conversion:

If the full stroke range is **250 inches** and the current position is **0x4FF** (1279 Decimal) then,

$$\left(\frac{1279 - 6}{4061} \right) \times 250 = 78.8 \text{ inches}$$

Changing the Cable Exit

Changing Measuring Cable Exit

To change the direction of the measuring cable, remove the 4 mounting bracket screws and rotate bracket to one of four available positions. See figures 1 - 4 on the following pages for mounting dimensions.

Changing Electrical Connector Direction

To change the position of the electrical connector, remove the 4 rear cover screws and carefully separate rear cover from the sensor body.

Rotate the rear cover to desired position being careful to not tangle the wiring harness that runs to the connector.

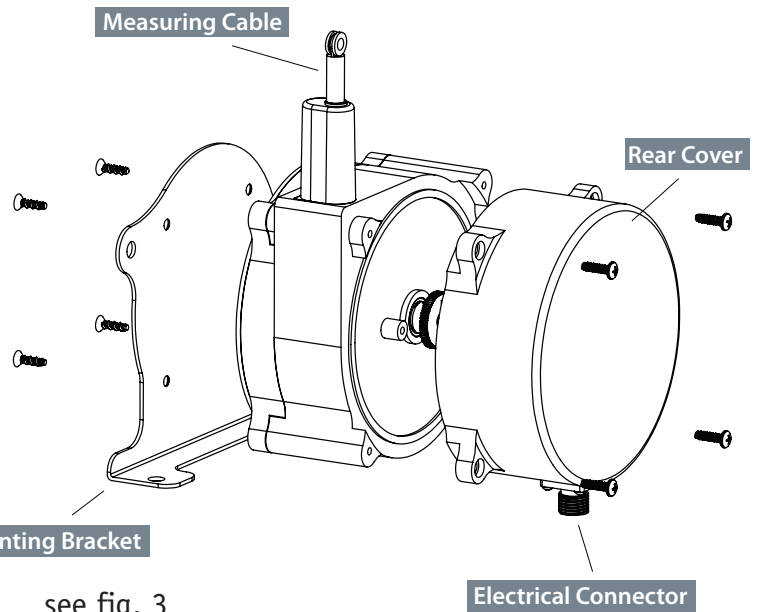

Cable Exit Direction Options

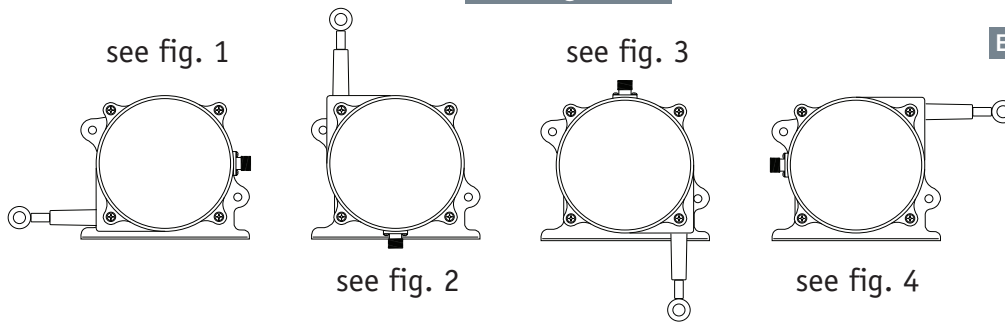
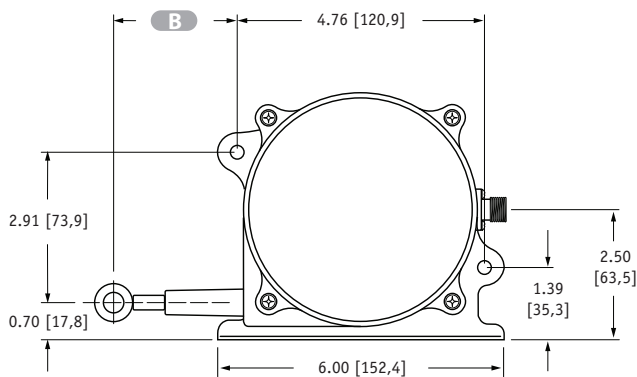
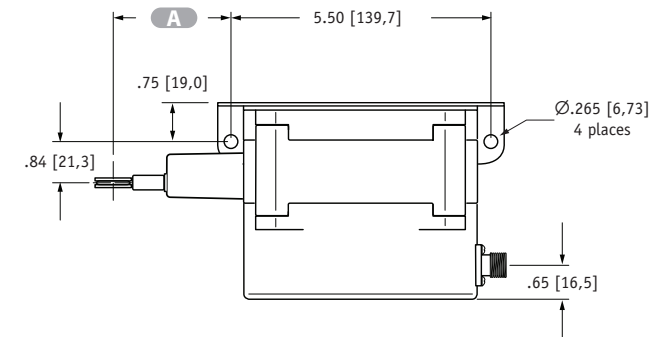
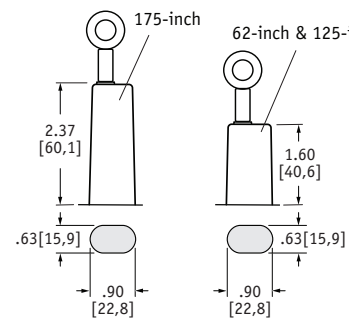

Fig. 1 - Outline Drawing (as shipped)



Model	A	B
125-inch	2.00 ±.13 [50,8 ±3,3]	2.37 ±.13 [60,22 ±3,3]
175-inch	2.87 ±.13 [72,8 ±3,2]	3.24 ±.13 [82,2 ±3,2]

Cable Guide Detail



Eyelet Detail

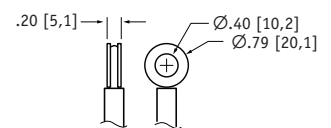

units are in inches [mm] tolerances are ± .04 [1,0] unless otherwise noted

Fig. 2 - "Up" Cable Exit Direction

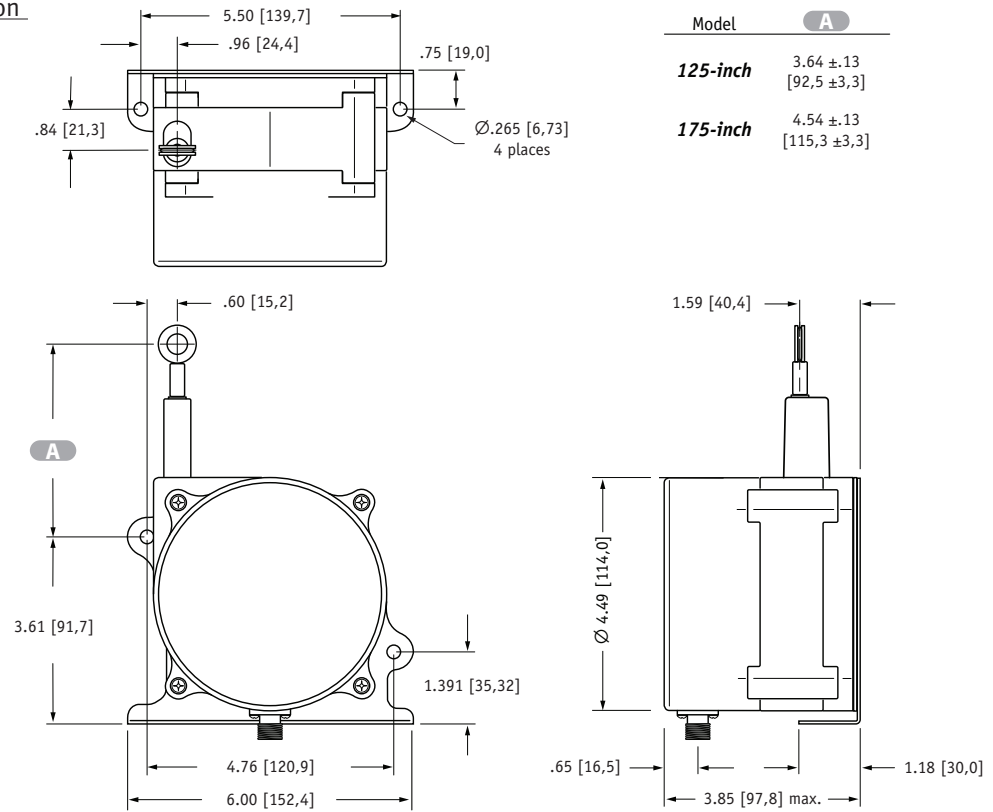

Fig. 3 - "Down" Cable Exit Direction

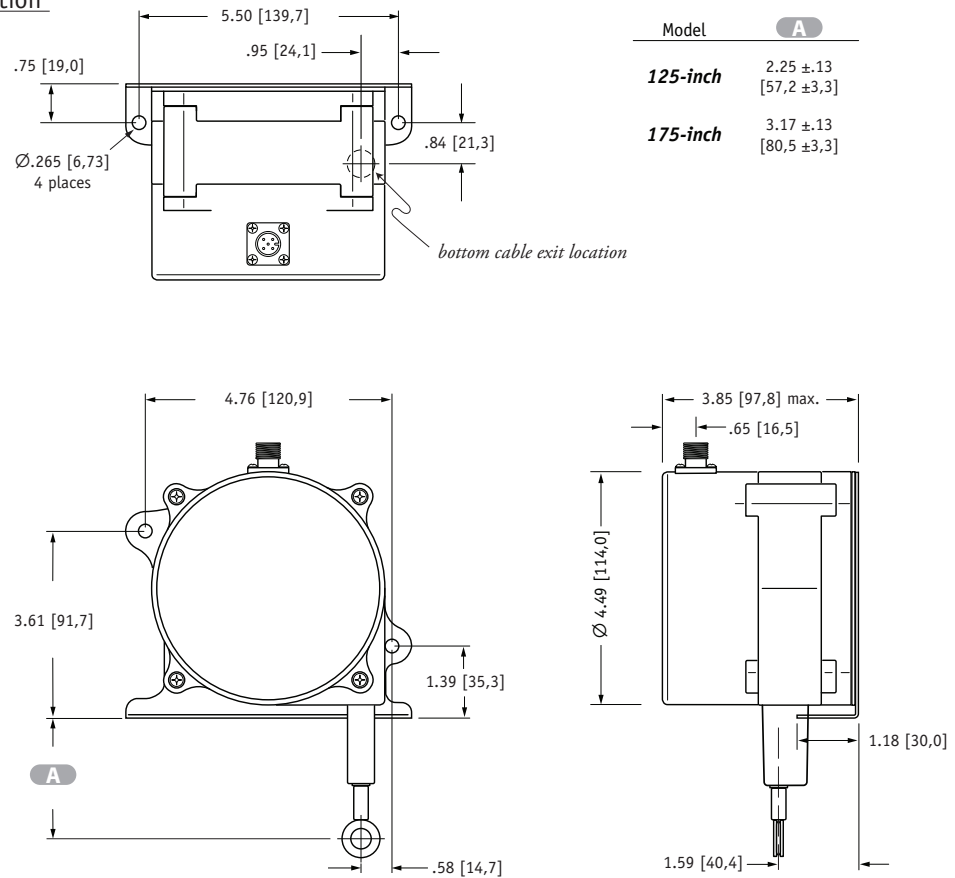
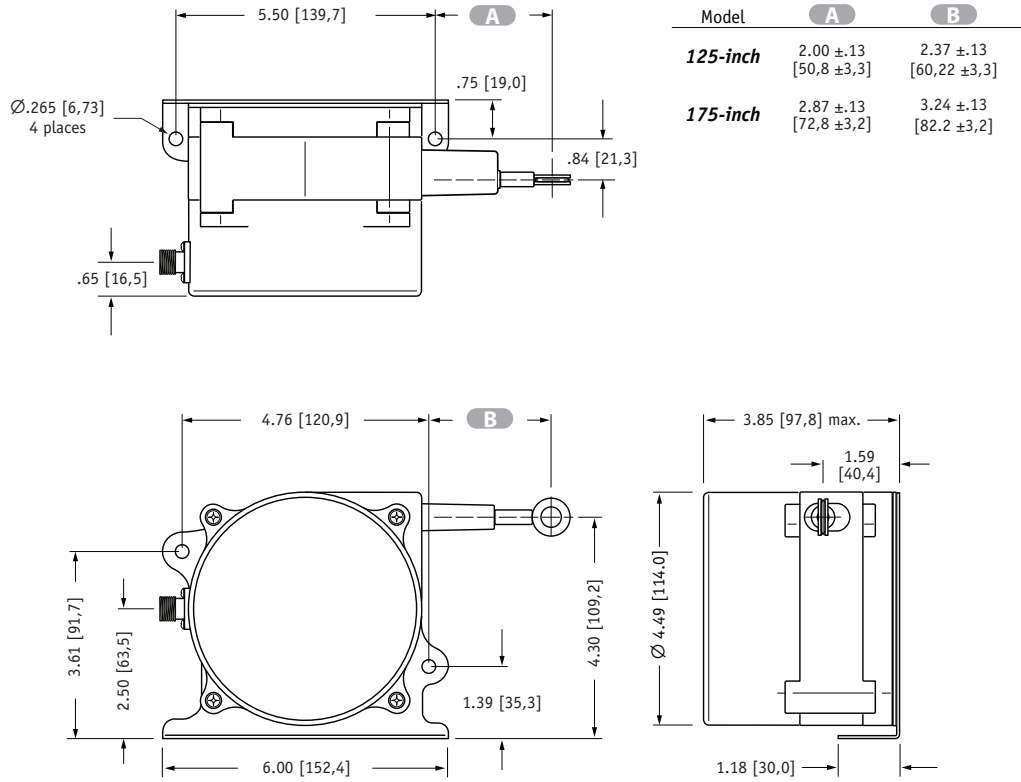

Fig. 4 - "Rear" Cable Exit Direction



units are in inches [mm] tolerances are ± .04 [1,0] unless otherwise noted

version: 1.0 last updated: June 15, 2016