

# PT8232

## Heavy Industrial • RS232

Absolute Linear Position to 60 inches (1524 mm)  
 Aluminum or Stainless Steel Enclosure Options  
 VLS Option To Prevent Free-Release Damage  
 IP67 • NEMA6 Protection

### GENERAL

Full Stroke Ranges	0-2 to 0-60 inches
Electrical Interface	RS232
Format	HEX
Accuracy	see ordering information
Repeatability	± 0.02% full stroke
Resolution	± 0.003% full stroke
Measuring Cable	stainless steel or thermoplastic
Enclosure Material	powder-painted aluminum or stainless steel
Sensor	plastic-hybrid precision potentiometer
Potentiometer Cycle Life	see ordering information
Maximum Retraction Acceleration	see ordering information
Weight, Aluminum (Stainless Steel) Enclosure	3 lbs. (6 lbs.), max.

### ELECTRICAL

Input Voltage	9...22 VDC
Input Current	40 mA
Baud Rate	9600 (selectable to 38.4K)
Update Rate	32 msec

### ENVIRONMENTAL

Environmental Suitability	NEMA 4X/6, IP 67
Operating Temperature	-40° to 200°F (-40° to 90°C)
Vibration	up to 10 g's to 2000 Hz maximum



20630 Plummer Street • Chatsworth, CA 91311 • Meas-Spec.com  
 tel: 800.423.5483 • +1.818.701.2750 • fax: +1.818.701.2799

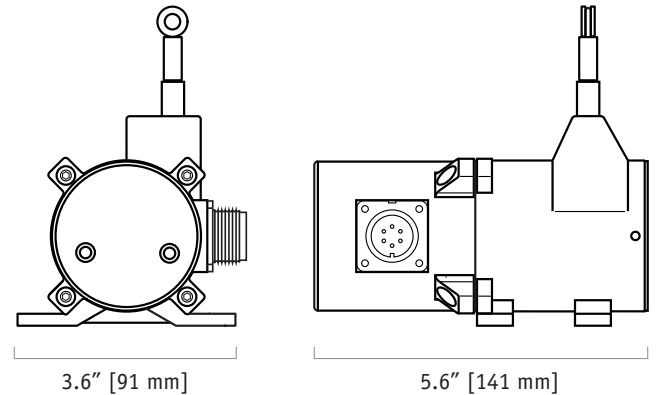

The PT8232 delivers position feedback via RS232 serial communication to your data acquisition or controller system. The PT8232 sends a raw 16-bit count from 0000H to FFFFH. Additionally this device can be set to continuously send data or send data only when polled.

As the internal position sensing element is a precision potentiometer, this transducer maintains current accurate position even during power loss and does not need to be reset to a "home" position.

### Output Signal:

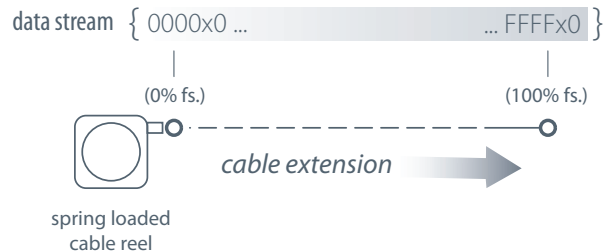

formally Celesco Transducer Products, Inc.  
 celesco.com • info@celesco.com

## I/O Format:

### Data Format

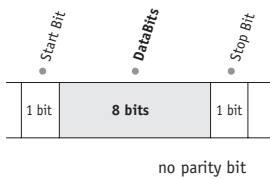

### Data Frame

6 byte Hex string:

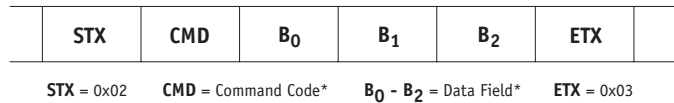

\*-see below

**Important!** All communications to/from the transducer are in **HEX!**

### User Commands:

Description	User Command				Sensor Response			
	<CMD>	<B <sub>0</sub> >	<B <sub>1</sub> >	<B <sub>2</sub> >	<CMD>	<B <sub>0</sub> >	<B <sub>1</sub> >	<B <sub>2</sub> >
Get Sensor Info	0x05	0x00	0x00	0x00	0x05	version <sup>(4)</sup>	date <sup>(5)</sup>	date <sup>(5)</sup>
Get Serial Number	0x15	0x00	0x00	0x00	0x15	serial number <sup>(3)</sup>		
Start Continuous Data	0x25	0x00	0x00	0x00	0x25	0x00	0x00	0x00
Stop Continuous Data	0x35	0x00	0x00	0x00	0x35	0x00	0x00	0x00
Get Position Data	0x45	0x00	0x00	0x00	0x45	CMC <sup>(1)</sup>	CMC <sup>(1)</sup>	status <sup>(2)</sup>

#### (1) CMC - Current Measurement Count (Position)

The Current Measurement Count (CMC) is the output data that indicates the present position of the measuring cable.

The CMC is a 16-bit value that occupies the first two bytes (B<sub>0</sub> and B<sub>1</sub>) of the data field. B<sub>0</sub> is the MSB (most significant byte) and B<sub>1</sub> is the LSB (least significant byte).

The CMC starts at 0000H with the measuring cable fully retracted and continues upward to the end of the stroke range stopping at FFFFH. This holds true for all ranges.

#### (2) Status

The status byte is used as a flag to indicate the validity of the position signal that the internal electronics receives from the potentiometer.

Flags are as follows:  
0x00 = GREEN, 0x55 = YELLOW, 0xAA = RED

A "green" flag shows everything OK. A "yellow" or "red" flag indicates that the sensor has either been extended beyond its range or that there is a problem with the potentiometer.

#### (3) Serial Number

Each sensor has its own unique serial number. This information can be retrieved by sending the sensor the "Get Serial Number" command.

The serial number is a 3 byte value from which ranges from 0 to 9999999 (decimal).

#### (4) Version

This is a single byte value (0-255 decimal) which indicates the currently installed firmware version of the sensor.

#### (5) Date

This is a 2 byte value showing the date of currently installed firmware. This value ranges from 01011 - 12319 (decimal). Format is MMDDYY. While the month and day are expressed as two digit numbers the year is expressed in a single digit only.

Example: 08054 = August 5, 2004

### Baud Rate

The baud rate can be set using switches 7 & 8 on the 8-pole DIP switch found on the rs232 controller board located inside the transducer.

DIP-7	DIP-8	baud rate
0	0	9600
1	0	19200
0	1	38400
1	1	9600



### RS232 Controller Board and DIP Switch Location

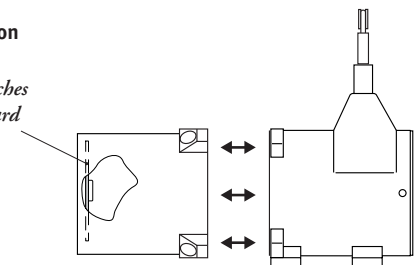
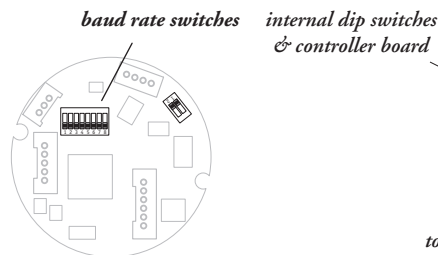

to gain access to the controller board, remove four Allen-Head Screws and remove rear cover.

**Outline Drawing:**

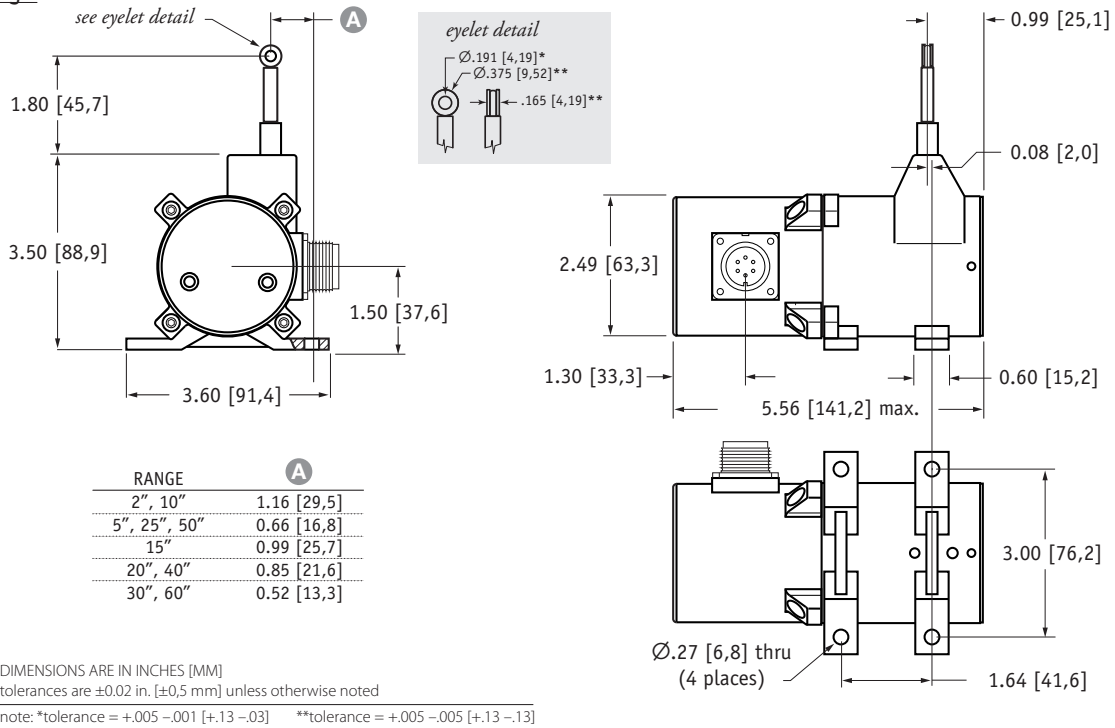

**Ordering Information:**

**Model Number:**

**PT8232** - **R** - **A** - **B** - **C** - **D** - **E**  
order code:

Sample Model Number:

**PT8232 - 50 - AL - N34 - T1 - CG - M6**

- R** range: 200 inches
- A** enclosure: aluminum
- B** measuring cable: .034 nylon-coated stainless
- C** measuring cable tension: standard
- D** cable guide: standard
- E** electrical connection: 6-pin plastic connector

**Full Stroke Range:**

<b>R</b> order code:	2	5	10	15	20	25	30	40	50	60
full stroke range, min:	2 in.	5 in.	10 in.	15 in.	20 in.	25 in.	30 in.	40 in.	50	60
accuracy (% of f.s.):	1.00%	1.00%	0.15%	0.15%	0.15%	0.15%	0.15%	0.10%	0.10%	0.10%
potentiometer cycle life*:	2.5 x 10 <sup>6</sup>	2.5 x 10 <sup>6</sup>	5 x 10 <sup>5</sup>	5 x 10 <sup>5</sup>	5 x 10 <sup>5</sup>	5 x 10 <sup>5</sup>	5 x 10 <sup>5</sup>	2.5 x 10 <sup>5</sup>	2.5 x 10 <sup>5</sup>	2.5 x 10 <sup>5</sup>

\*-1 cycle is defined as the travel of the measuring cable from full retraction to full extension and back to full retraction

**Enclosure Material:**

<b>A</b> order code:	AL	SS	316
	powder-painted aluminum	303 stainless steel	316 stainless steel

**Measuring Cable:**

<b>B</b> order code:	N34	S47	S31	V62
cable construction:	Ø.034-inch nylon-coated stainless steel rope	Ø.047-inch bare stainless steel rope	Ø.031-inch bare stainless steel rope	Ø.058-inch PVC jacketed vectra fiber rope
available ranges:	all ranges	5, 15, 20, 25, 30-inch only	40, 50, 60-inch only	thru 30 inches only
general use:	indoor	outdoor, debris, high temperature	outdoor, debris, high temperature	high voltage or magnetic field

Ordering Information (cont.):

**Measuring Cable Tension:**

		T1		T2		T3	
		standard tension		medium tension		high tension	
full stroke range cable tension specifications	2, 10-inch:	39 oz.	65 oz.	116 oz.			
	15-inch:	26 oz.	43 oz.	77 oz.			
	20, 40-inch:	20 oz.	33 oz.	60 oz.			
	5, 25, 50-inch:	16 oz.	26 oz.	47 oz.			
	30, 60-inch:	13 oz.	22 oz.	40 oz.			
		maximum acceleration		maximum acceleration		maximum acceleration	
		tension tolerance: ± 50%					
aluminum enclosure:		15 g	25 g	40 g			
stainless steel enclosure:		6 g	12 g	18 g			

**Cable Guide Options:**

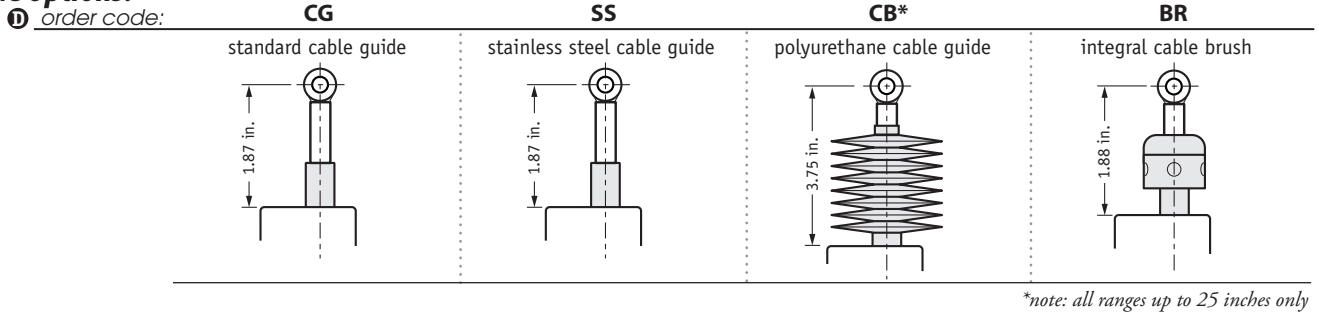

**Electrical Connection:**

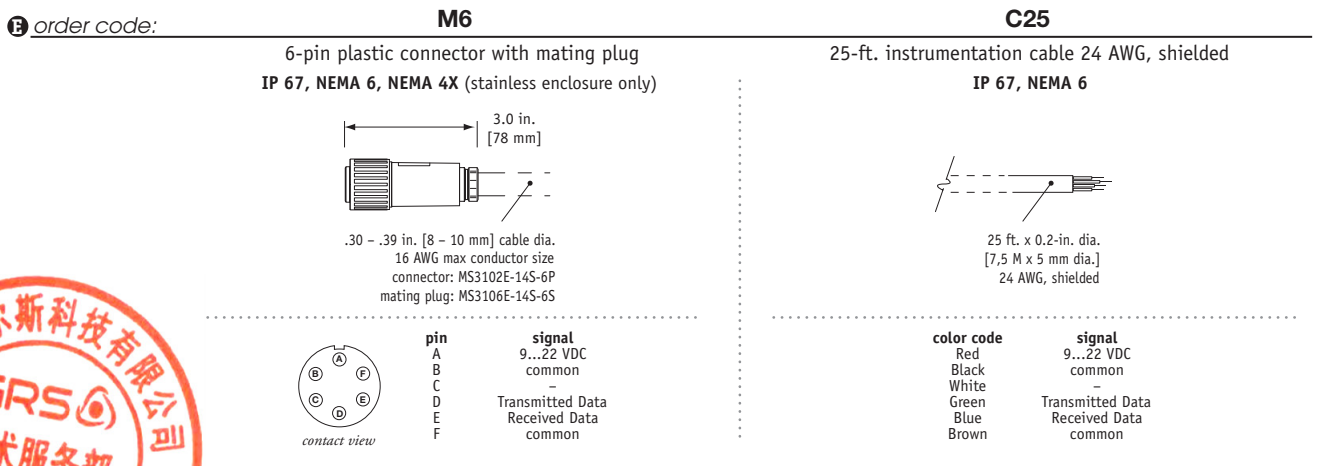

version: 8.0 last updated: March 26, 2015