

# Cable-Extension Position Transducer

CANbus • SAE J1939

Ranges: 0-10 to 0-250 inches

Industrial Grade • High Cycle Applications

# PT5CN

## Specification Summary:

### GENERAL

Full Stroke Ranges..... 0-10 to 0-250 inches  
 Electrical Interface..... CANbus SAE J1939  
 Protocol..... Proprietary B  
 Accuracy.....  $\pm 0.25\%$  to  $\pm 0.10\%$  full stroke  
 Repeatability.....  $\pm 0.02\%$  full stroke  
 Resolution.....  $\pm 0.003\%$  full stroke  
 Measuring Cable..... stainless steel or thermoplastic  
 Enclosure Material..... hard anodized aluminum  
 Sensor..... plastic-hybrid precision potentiometer  
 Potentiometer Cycle Life..... *see ordering information*  
 Maximum Retraction Acceleration..... *see ordering information*  
 Weight..... 5 lbs. max.

### ELECTRICAL

Input Voltage..... 7 - 18 VDC  
 Input Current..... 60 mA max.  
 Baud Rate..... 125K, 250K, or 500K via DIP switches  
 Update Rate..... 10 ms. (20 ms. available—*contact factory*)

### ENVIRONMENTAL

Environmental Suitability..... NEMA 4/6, IP 65/67  
 Operating Temperature..... -40° to 185°F (-40° to 85°C)  
 Vibration..... up to 10 G's to 2000 Hz maximum

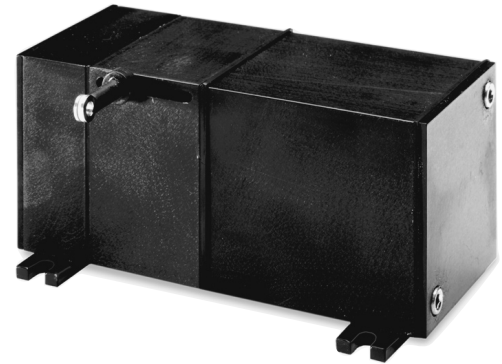

The PT5CN cable extension position transducer communicates linear position via the CANbus SAE J1939 interface providing a precision position feedback to your PLC. The PT5DN is offered in full stroke ranges up to 250 inches and a thermoplastic measuring cable for high cycle and rugged applications.

Because the PT5CN uses a potentiometer as its sensing element, the position signal is "absolute" and does not have to be reset to a "home" position upon startup.

### Outline Drawing

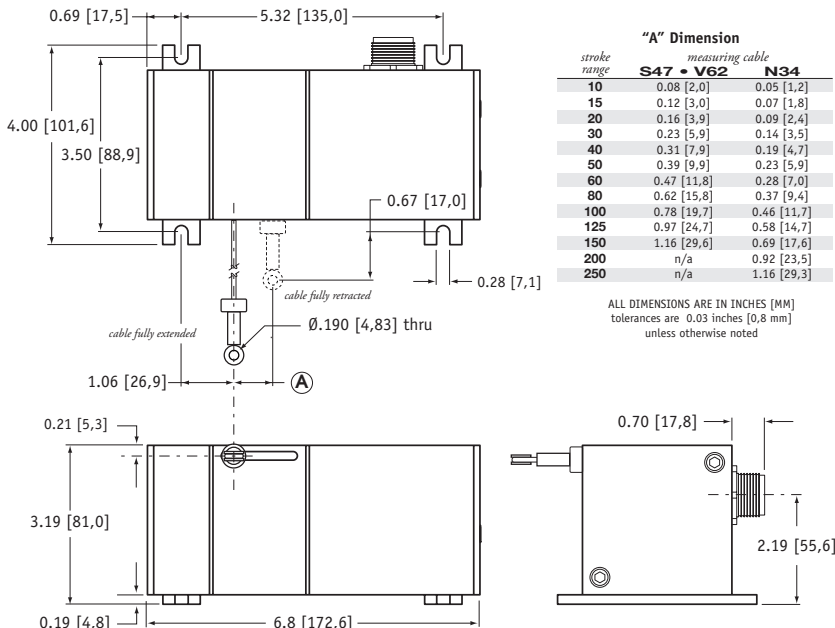

### Output Signal

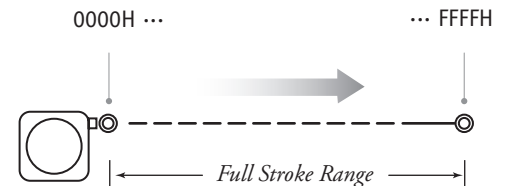

Celeco Transducer Products, Inc.  
 20630 Plummer Street • Chatsworth, CA 91311  
 tel: 800.423.5483 • +1.818.701.2750 • fax: +1.818.701.2799



celesco  
 celesco.com • info@celesco.com

# I/O Format and Settings

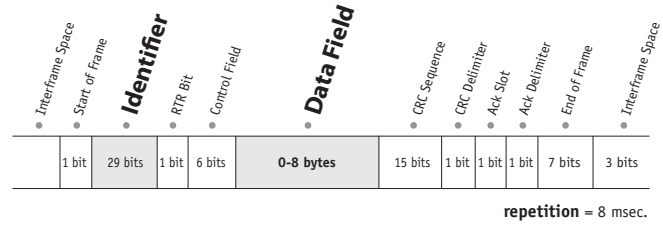

## • Identifier

	Message Priority				Future Use				J1939 Reference Proprietary B								Data Field Type*				Not Used		Node ID**										
Example –	1	0	0	0	0	0	1	1	1	1	1	1	1	1	1	1	0	1	0	1	0	0	1	1	0	0	1	1	1	1	1	1	1
Identifier Bit No. –	28	27	26	25	24	23	22	21	20	19	18	17	16	15	14	13	12	11	10	9	8	7	6	5	4	3	2	1	0				
Hex Value –	0				F				F				5				3				3		F										

\*Sensor field data can be factory set to customer specific value. \*\*Customer defined, set via Dips 1-6. Bit values shown for example only, see Address Setting below.

## • Data Field

- B<sub>0</sub> = LSB current % of measurement range byte
- B<sub>1</sub> = MSB current % of measurement range byte
- B<sub>2</sub> = LSB current measurement count byte
- B<sub>3</sub> = MSB current measurement count byte

- B<sub>4</sub> = error flag
- B<sub>5</sub> = error flag
- B<sub>6</sub> = LSB velocity data byte
- B<sub>7</sub> = MSB velocity data byte

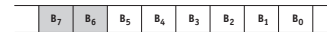
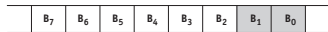
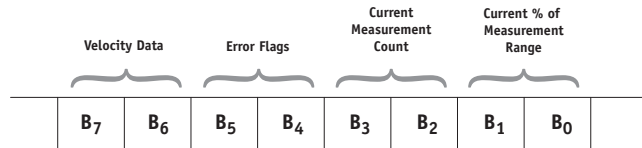

### Current Measurement Count

The Current Measurement Count (CMC) is the output data that indicates the present position of the measuring cable. The CMC is a 16-bit value that occupies bytes B<sub>2</sub> and B<sub>3</sub> of the data field. B<sub>2</sub> is the LSB (least significant byte) and B<sub>3</sub> is the MSB (most significant byte).

The CMC starts at 0x0000 with the measuring cable fully retracted and continues upward to the end of the stroke range stopping at 0xFFFF. This holds true for all ranges.

### Converting CMC to Linear Measurement

To convert the current measurement count to inches or millimeters, simply divide the count by 65,535 (total counts over the range) and then multiply that value by the full stroke range:

$$\left( \frac{\text{current measurement count}}{65,535} \right) \times \text{full stroke range}$$

Sample Conversion:

If the full stroke range is **30 inches** and the current position is **0x0FF2** (4082 Decimal) then,

$$\left( \frac{4082}{65,535} \right) \times 30.00 \text{ inches} = 1.87 \text{ inches}$$

If the full stroke range is **625 mm** and the current position is **0x0FF2** (4082 Decimal) then,

$$\left( \frac{4082}{65,535} \right) \times 625 \text{ mm} = 39 \text{ mm}$$

### Current % of Measurement Range

The Current % of Measurement Range is a 2-byte value that expresses the current linear position as a percentage of the entire full stroke range. Resolution is .1 % of the full stroke measurement range.

This value starts at 0x0000 at the beginning of the stroke and ends at 0x03E8.

Example:

Hex	Decimal	Percent
0000	0000	0.0%
0001	0001	0.1%
0002	0002	0.2%
...	...	...
03E8	1000	100.0%



### Error Flags

**0x55** (yellow LED on controller board) indicates that the sensor has begun to travel beyond the calibrated range of the internal position potentiometer.

**0xAA** (red LED on controller board) indicates that the sensor has moved well beyond the calibrated range of the internal position potentiometer.

If either error flag occurs within the full stroke range of the sensor, the unit should be returned to the factory for repair and recalibration.

### Velocity

Data in bytes B<sub>7</sub> - B<sub>6</sub> is the change in the CMC (current measurement count) over a 100 msec time period. This data can then be used to calculate velocity in a post processing operation.

B <sub>7</sub> - B <sub>6</sub> HEX (Decimal)	max "reverse" velocity	max "forward" velocity	Velocity (cts./100 msec.)
0x0000 (0)	▲	▼	- 32767 counts
0x7FFF (32767)			"0" counts (no change)
0xFFFF (65535)			32767 counts

### Velocity Calculation

$$\left( \frac{\text{count change} - 32767}{.1 \text{ sec. time period}} \right) \times \left( \frac{\text{full stroke range}}{65,535} \right)$$

#### Sample Calculations

Cable Extension (positive direction):

**B<sub>7</sub>-B<sub>6</sub> = 0x89C6** (43462 Dec), **full stroke = 60 in.**

$$\left( \frac{35270 - 32767}{.1 \text{ sec}} \right) \times \left( \frac{60 \text{ in.}}{65,535} \right) = 22.92 \text{ in. / sec.}$$

Cable Retraction (negative direction):

**B<sub>7</sub>-B<sub>6</sub> = 0x61A8** (25000 Dec), **full stroke = 60 in.**

$$\left( \frac{25000 - 32767}{.1 \text{ sec}} \right) \times \left( \frac{60 \text{ in.}}{65,535} \right) = -71.11 \text{ in. / sec.}$$

### Setting the Address (Node ID) and Baud Rate

#### Address Setting (Node ID)

The Address Setting (Node ID) is set via 6 switches located on the 8-pole DIP switch found on the DeviceNET controller board located inside the transducer.

The DIP switch settings are binary starting with switch number 1 (= 2<sup>0</sup>) and ending with switch number 6 (= 2<sup>5</sup>).

#### Baud Rate

The transmission baud rate may be either factory preset at the time of order or set manually at the time of installation.

The baud rate can be set using switches 7 & 8 on the 8-pole DIP switch found on the DeviceNET controller board located inside the transducer.

#### CANBus Controller Board

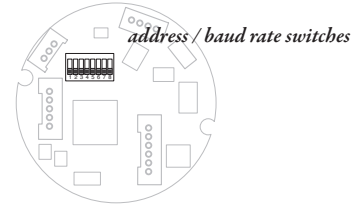

DIP-1 (2 <sup>0</sup> )	DIP-2 (2 <sup>1</sup> )	DIP-3 (2 <sup>2</sup> )	DIP-4 (2 <sup>3</sup> )	DIP-5 (2 <sup>4</sup> )	DIP-6 (2 <sup>5</sup> )	address (decimal)
0	0	0	0	0	0	0
1	0	0	0	0	0	1
0	1	0	0	0	0	2
...	...	...	...	...	...	...
1	1	1	1	1	1	63

DIP-7	DIP-8	baud rate
0	0	125k
1	0	250k
0	1	500k
1	1	125k



#### internal dip switches & controller board

to gain access to the controller board, remove four Allen-Head Screws and remove end cover bracket.

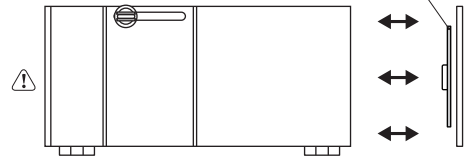

**Caution! Do Not Remove Spring-Side End Cover**  
removing spring-side end cover could cause spring to become unseated and permanently damaged.

### Ordering Information:

#### Model Number:



Sample Model Number:

**PT5CN - 50 - S47 - FR - J - 500 - 32 - SC5**

- R** range: 50 inches
- A** measuring cable: .047 stainless steel
- B** measuring cable exit: front
- C** interface: CANbus SAE J1939
- D** baud rate: 500 k bits/sec.
- E** node ID: 32 decimal
- F** electrical connection: 5-meter cordset with straight plug

#### Full Stroke Range:

<b>R</b> order code:	10	15	20	25	30	40	50	60	80	100	125	150	200	250	
full stroke range, min:	10 in.	15 in.	20 in.	25 in.	30 in.	40 in.	50 in.	60 in.	80 in.	100 in.	125 in.	150 in.	200 in.	250 in.	
accuracy (±% of f.s.):	.75%	.6%	.5%	.5%	.5%	.3%	.3%	.25%	.25%	.25%	.25%	.18%	.18%	.18%	
repeatability (±% of f.s.):	.1%	.1%	.05%	.05%	.05%	.05%	.05%	.02%	.02%	.02%	.02%	.02%	.02%	.02%	
potentiometer cycle life:	2,500,000 cycles					500,000 cycles					250,000 cycles				
cable tension (20%):	41 ounces										21 ounces				
max. cable velocity/acceleration:	300 in./sec • 5 G's										120 in./sec • 2 G's				

#### Measuring Cable:

**A** order code:

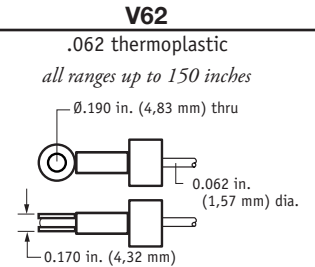
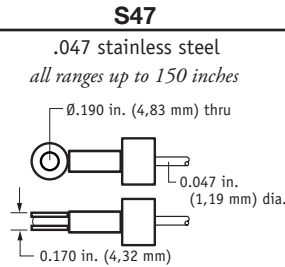
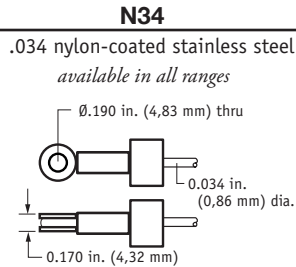

**Ordering Information (cont.)**

**Cable Exit:**

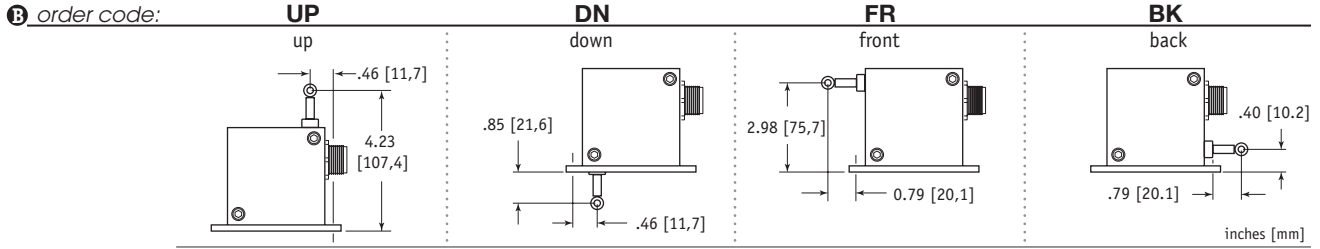

**Baud Rate:**

① order code:

125	250	500
125 kbaud	250 kbaud	500 kbaud

**Node ID:**

② order code:

0	1	2	...	62	63
select address (0 - 63 Decimal)					

**Electrical Connection:**

④ order code:

blank	MC5	SC5	NC5																		
5-pin micro-connector <i>(no mating plug supplied)</i>	5-pin micro-connector w/ mating plug	5-pin micro-connector and 5 meter length cordset w/straight mating plug	5-pin micro-connector and 5 meter length cordset w/90° mating plug																		
		<table border="1"> <thead> <tr> <th>pin</th> <th>signal</th> <th>wire color</th> </tr> </thead> <tbody> <tr> <td>1</td> <td>drain</td> <td>brown</td> </tr> <tr> <td>2</td> <td>V+</td> <td>white</td> </tr> <tr> <td>3</td> <td>V-</td> <td>blue</td> </tr> <tr> <td>4</td> <td>Can-H</td> <td>black</td> </tr> <tr> <td>5</td> <td>Can-L</td> <td>grey</td> </tr> </tbody> </table>	pin	signal	wire color	1	drain	brown	2	V+	white	3	V-	blue	4	Can-H	black	5	Can-L	grey	
pin	signal	wire color																			
1	drain	brown																			
2	V+	white																			
3	V-	blue																			
4	Can-H	black																			
5	Can-L	grey																			



version: 5.1 last updated: December 3, 2010