

# RT9510

0–90° to 0–50 Turns • 0...5, 0...10 Vdc

Industrial Grade Rotational Position Sensor  
Absolute Rotary Position up to 50 turns  
Aluminum or Stainless Steel Enclosure Options  
IP68 / NEMA 6



## GENERAL

Full Stroke Range Options	0-0.25 to 0-50 turns
Output Signal Options	0...5, 0...10 Vdc
Accuracy	see ordering information
Repeatability	± 0.05% full stroke
Resolution	essentially infinite
Enclosure Material Options	powder-painted aluminum or stainless steel
Sensor	plastic-hybrid precision potentiometer
Potentiometer Cycle Life	see ordering information
Shaft Loading	up to 35 lbs. radial and 5 lbs. axial
Weight, Aluminum (Stainless Steel) Enclosure	3 lbs. (6 lbs.) max.

## ELECTRICAL

Input Voltage	14.5-40 VDC (10.5-40 VDC for 0...5 volt output)
Input Current	10 mA max.
Output Impedance	1000 ohms
Maximum Load	5000 ohms.
Zero Adjustment	from factory set zero to 50% of full stroke range
Span Adjustment	to 50% of factory set span

## ENVIRONMENTAL

Enclosure	NEMA 4/4X/6, IP 67/68
Operating Temperature	-40° to 200°F (-40° to 90°C)
Vibration	up to 10 g to 2000 Hz maximum

## EMC COMPLIANCE PER DIRECTIVE 89/336/EEC

Emission/Immunity	EN50081-2/EN50082-2
-------------------	---------------------

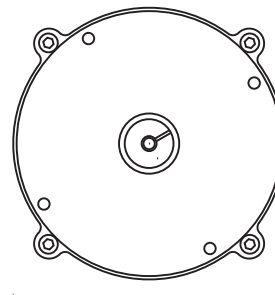

4.5" [114 mm]

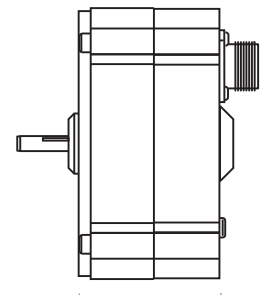

2.4" [59 mm]

The RT9510 is an incredibly simple device which provides a regulated 0...10 VDC rotational-position feedback signal with a 14.5...40 VDC unregulated input voltage.

This innovative sensor from Celesco, designed to meet tough NEMA-4 and IP67 environmental standards, is available in full-stroke measurement ranges of 1/4 to 50 turns. Because the sensor is potentiometric, the RT9510 is absolute and will maintain position information even after a loss of power.

## Output Signal:



\*Optional 0...5 Vdc output signal available.

20630 Plummer Street • Chatsworth, CA 91311  
tel: 800.423.5483 • +1.818.701.2750 • fax: +1.818.701.2799



celesco.com • info@celesco.com

**Outline Drawing:**

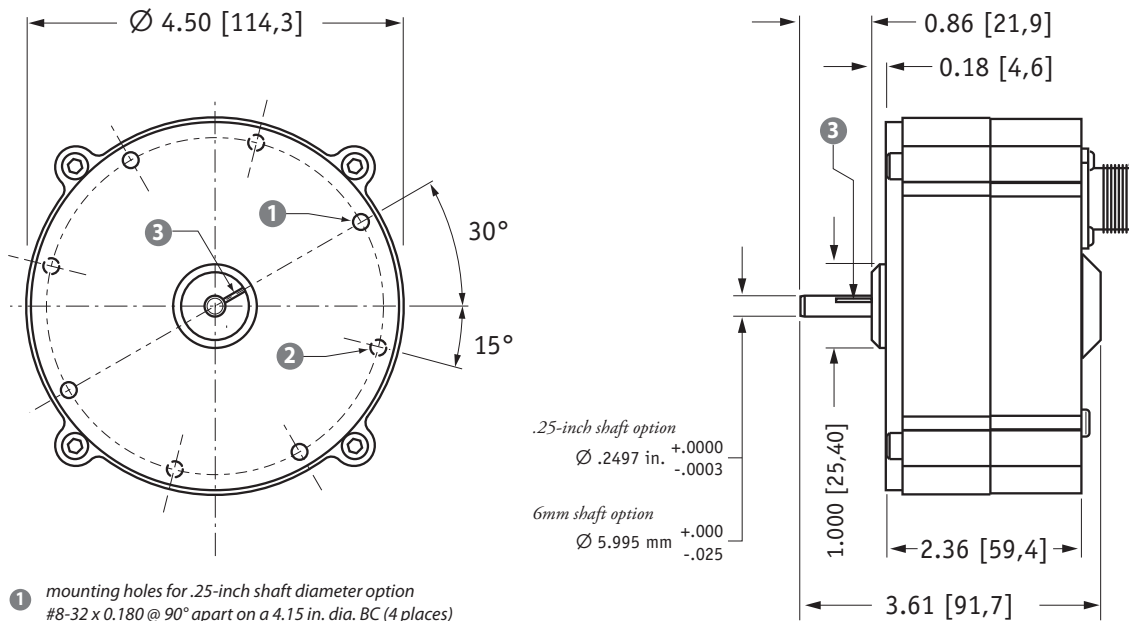

- 1 mounting holes for .25-inch shaft diameter option  
#8-32 x 0.180 @ 90° apart on a 4.15 in. dia. BC (4 places)
- 2 mounting holes for 6-mm shaft diameter option  
M4 x 4,5 mm @ 90° apart on a 105,4 mm dia. BC (4 places)
- 3 reference mark  
full counter-clockwise position - align mark on shaft to mark on face for start of measurement range

DIMENSIONS ARE IN INCHES [MM]  
tolerances are  $\pm 0.02$  in. [ $\pm 0,5$  mm] unless otherwise noted

**Ordering Information:**

**Model Number:**

**RT9510-** \_\_\_\_\_ **1** - **1** \_\_\_\_\_ **0**  
order code:                    R                    A                    B                    C                    D                    E                    F                    G

Sample Model Number:

**RT9510 - 0005 - 111 - 1110**

- R range: 5 turns (clockwise shaft rotations)
- A enclosure: aluminum
- B shaft diameter: .25 inches
- F output signal: 0...10 VDC signal increasing clockwise
- F electrical connection: 6-pin plastic connector

**Full Stroke Range:**

R order code:	R125	0R25	0R50	0001	0002	0003	0005	0010	0020	0030	0050
clockwise shaft rotations, min:	0.125	0.25	0.50	1	2	3	5	10	20	30	50
accuracy (% of f.s.):	0.3%	0.3%	0.3%	0.3%	0.3%	0.3%	0.2%	0.15%	0.15%	0.15%	0.15%
potentiometer cycle life*:	$2.5 \times 10^6$	$2.5 \times 10^6$	$2.5 \times 10^6$	$2.5 \times 10^6$	$2.5 \times 10^6$	$2.5 \times 10^6$	$5 \times 10^5$	$2.5 \times 10^5$	$2.5 \times 10^5$	$2.5 \times 10^5$	$2.5 \times 10^5$

\*-number of times the sensor shaft can be cycled back and forth from beginning to end and back to the beginning before any measurable signal degradation may occur.

**Enclosure Material:**



A order code:	1	2
	powder-painted aluminum	303 stainless steel

**Shaft Diameter:**

B order code:	1	2	3	4
	0.25-in. diameter	6 mm diameter	0.25-in. dia. w/flats	6 mm dia. w/flats
	.2497 in. (+.0000 -.0003)	5.995 mm (+.000 -.025)	0.33 in. $\leftarrow$ 0.025 in.	8.4 mm $\leftarrow$ 0.64 mm

Ordering Information (cont.):

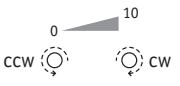
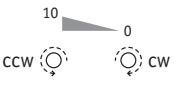

**Output Signals:**

<b>order code:</b>	<b>1</b>	<b>2</b>	<b>3</b>	<b>4</b>
output signal options:	0...10 VDC 	10...0 VDC 	0...5 VDC 	5...0 VDC 
input voltage:	14.5...40 VDC		10.5...40 VDC	

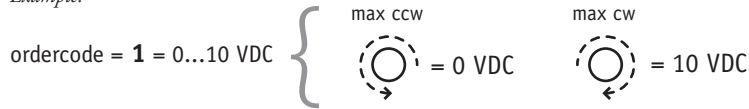
Example:

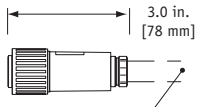
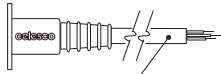
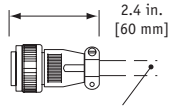

**Electrical Connection:**

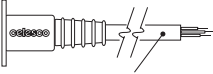
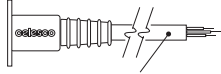
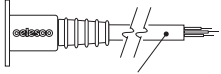
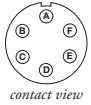
<b>order code:</b>	<b>1</b>	<b>2</b>	<b>3</b>	<b>4</b>																									
	6-pin plastic connector w/mating plug <b>IP 67, NEMA 4X**, 6</b>	10-ft. [3 M] waterproof cable <b>IP 67, NEMA 4X**, 6</b>	6-pin metal connector w/mating plug <b>IP 65, NEMA 4</b>	25-ft. [7.5 M] instrumentation cable <b>IP 67, NEMA 6</b>																									
	 1/2 - 5/16" [14 - 8 mm] cable dia. 16 AWG max conductor size connector: MS3102E-14S-6P mating plug: MS3106E-14S-6S	 10 ft. x 0.4-in. dia. [3 M x 10 mm dia.] 18 AWG, type SJTW	 3/8-in. [9 mm] max cable dia. 16 AWG max conductor size connector: MS3102E-14S-6P mating plug: MS3106E-14S-6S	 25 ft. x 0.2-in. dia. [7.5 M x 5 mm dia.] 24 AWG, shielded																									
<b>order code:</b>	<b>5</b>	<b>6</b>	<b>7</b>																										
	100-ft. [30 M] waterproof cable <b>IP 67, NEMA 4X**, 6</b>	10-ft. [3 M] <b>pressure tested*</b> waterproof cable <b>IP 68, NEMA 4X**, 6P</b>	100-ft. [30 M] <b>pressure tested*</b> waterproof cable <b>IP 68, NEMA 4X**, 6P</b>																										
	 100 ft. x 0.4-in. dia. [30 M x 10 mm dia.] 18 AWG, type SJTW	 10 ft. x 0.4-in. dia. [3 M x 10 mm dia.] 18 AWG, type SJTW	 100 ft. x 0.4-in. dia. [30 M x 10 mm dia.] 18 AWG, type SJTW																										
	<b>6-pin Mating Plug</b> <table border="1"> <thead> <tr> <th>pin</th> <th>signal</th> </tr> </thead> <tbody> <tr> <td>A</td> <td>input voltage</td> </tr> <tr> <td>B</td> <td>output signal</td> </tr> <tr> <td>C</td> <td>common</td> </tr> </tbody> </table>  <i>contact view</i>		pin	signal	A	input voltage	B	output signal	C	common	<b>Waterproof Cable</b> <table border="1"> <thead> <tr> <th>color code</th> <th>signal</th> </tr> </thead> <tbody> <tr> <td>WHITE</td> <td>input voltage</td> </tr> <tr> <td>GREEN</td> <td>output signal</td> </tr> <tr> <td>BLACK</td> <td>common</td> </tr> </tbody> </table>		color code	signal	WHITE	input voltage	GREEN	output signal	BLACK	common	<b>Instrumentation Cable</b> <table border="1"> <thead> <tr> <th>color code</th> <th>signal</th> </tr> </thead> <tbody> <tr> <td>RED</td> <td>input voltage</td> </tr> <tr> <td>GREEN</td> <td>output signal</td> </tr> <tr> <td>BLACK</td> <td>common</td> </tr> </tbody> </table>	color code	signal	RED	input voltage	GREEN	output signal	BLACK	common
pin	signal																												
A	input voltage																												
B	output signal																												
C	common																												
color code	signal																												
WHITE	input voltage																												
GREEN	output signal																												
BLACK	common																												
color code	signal																												
RED	input voltage																												
GREEN	output signal																												
BLACK	common																												

\*-Test pressure: 100 feet [30 meters] H<sub>2</sub>O (40 PSID); Test Medium: Air; Duration: 2 hours. \*\*-Applies to stainless steel enclosure only.

## Output Signal Selection:

The output signal direction can be reversed at any time by simply changing the dip-switch settings found on the internal signal board. After the settings have been changed, adjustment of the Zero and Span trimpots will be required to precisely match signal values to the beginning and end points of the stroke.

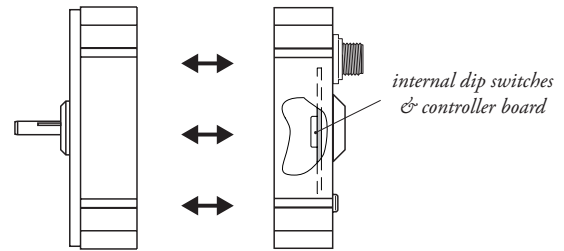
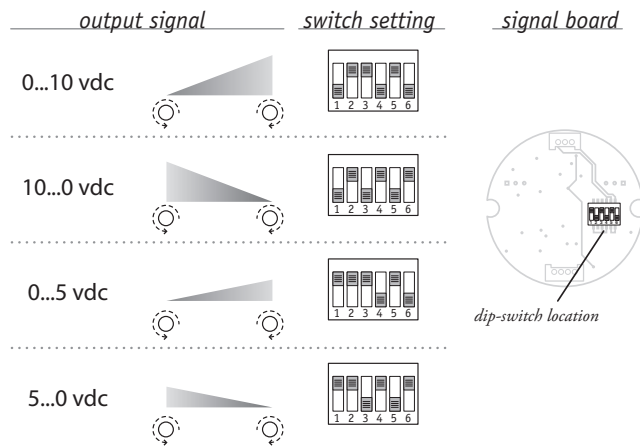

To gain access to the signal board, remove four Allen-Head Screws and separate the two case halves.



version: 4.0 last updated: March 1, 2014